

# INSPIRE-ROBOTS

## PRODUCT SELECTION GUIDE

Micro Linear Servo Actuator | The Dexterous Hands | Electric Gripper

Web: [en.inspire-robots.com](http://en.inspire-robots.com)

E-mail: [sales@inspire-robots.com](mailto:sales@inspire-robots.com)

Phone: +86 131-6166-5075

Address (Beijing): A3-4 Innovation Park, No.69 Yangzhuang Street,  
Shijingshan District, Beijing, China.

Office (Shenzhen): 5B06, Building 5 Phase 1, Shenzhen Software  
Park, Yuehai Street, Nanshan District, Shenzhen, China.





# ABOUT INSPIRE-ROBOTS

Smaller and Higher-precision Motion Control Experts

INSPIRE-ROBOTS is specializing in developing and manufacturing the micro high precision motion control components. Our product includes the Micro Linear Servo Actuator and Dexterous Hands, with unique advantages in micro-size, high precision and force control.

The products are compliance with the CE, RoHS and FCC certificates, which are widely used in robotics, new energy, 3C electronics, semiconductors and biomedical fields.

We are committed to providing high performance solutions and more possibilities for the companies that need precision control but are limited by the size of devices.

# Products and Application

INSPIRE-ROBOTS' products can meet the demand in the fields such as Robotics, New energy, Biomedical, Education&Research, with an emphasis in micro servo motion and precision force control.

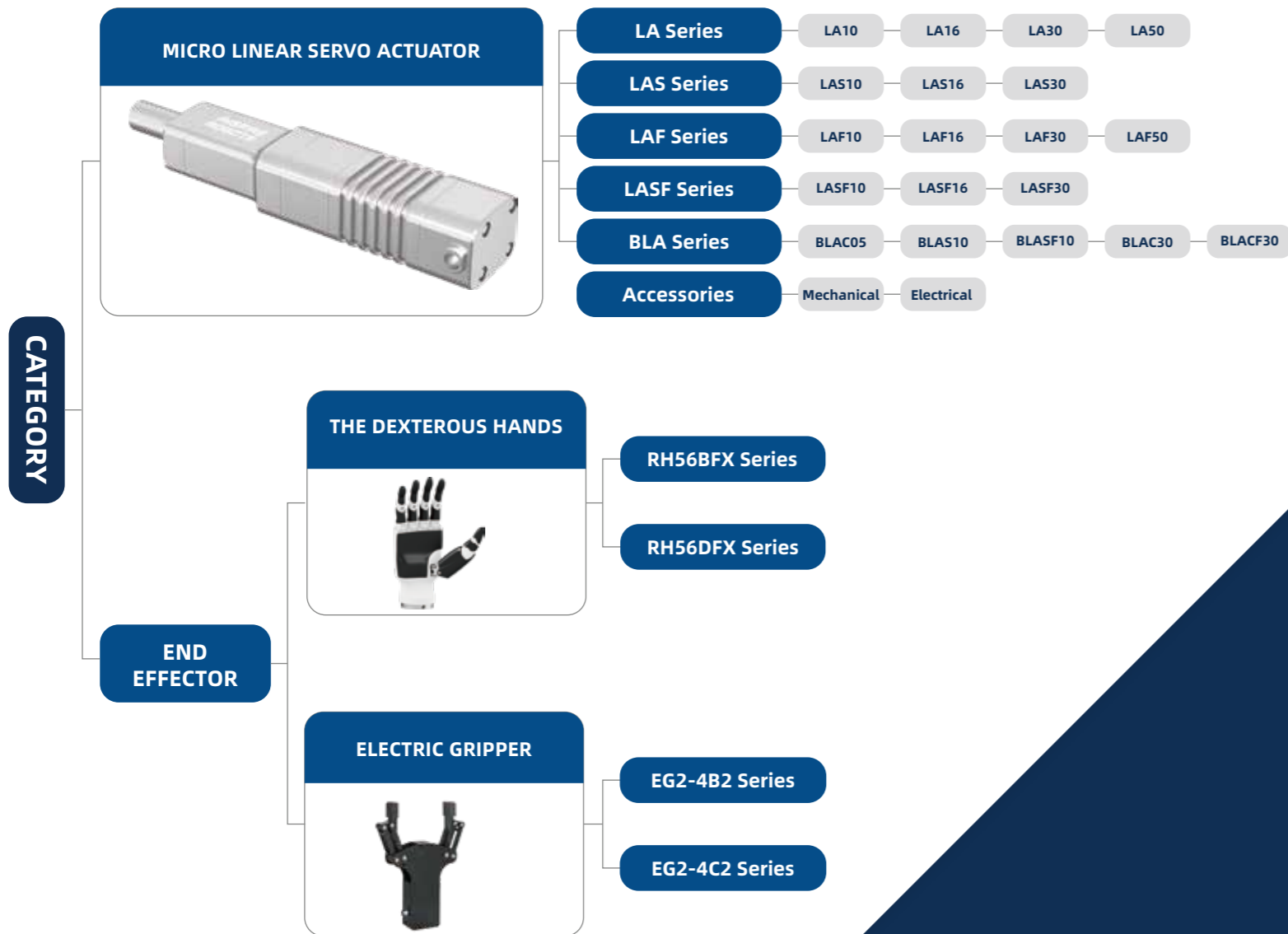

# CATALOG

01/ About Inspire-Robots	01
02/ Micro Linear Servo Actuator	03
Applications	05
Series	07
LA Series	09
LAS Series	17
LAF Series	23
LASF Series	27
BLA Series	30
Accessories	35
03/ The Dexterous Hands	37
04/ Electric Gripper	42



# MICRO LINEAR SERVO ACTUATOR

Micro Linear Servo Actuator is a small integrated system combining core-less motor, precision planetary reducer, position sensor, precision screw mechanism and closed-loop control system in a single package. Its compact dimensions, large load capacity, and high precision at any point throughout its stroke range enables it to act as a core component in electromechanical systems such as robots, medical equipment, and industrial equipment. A built-in absolute position sensor enables the retention of position information even during a power loss, without the need for a reference point.

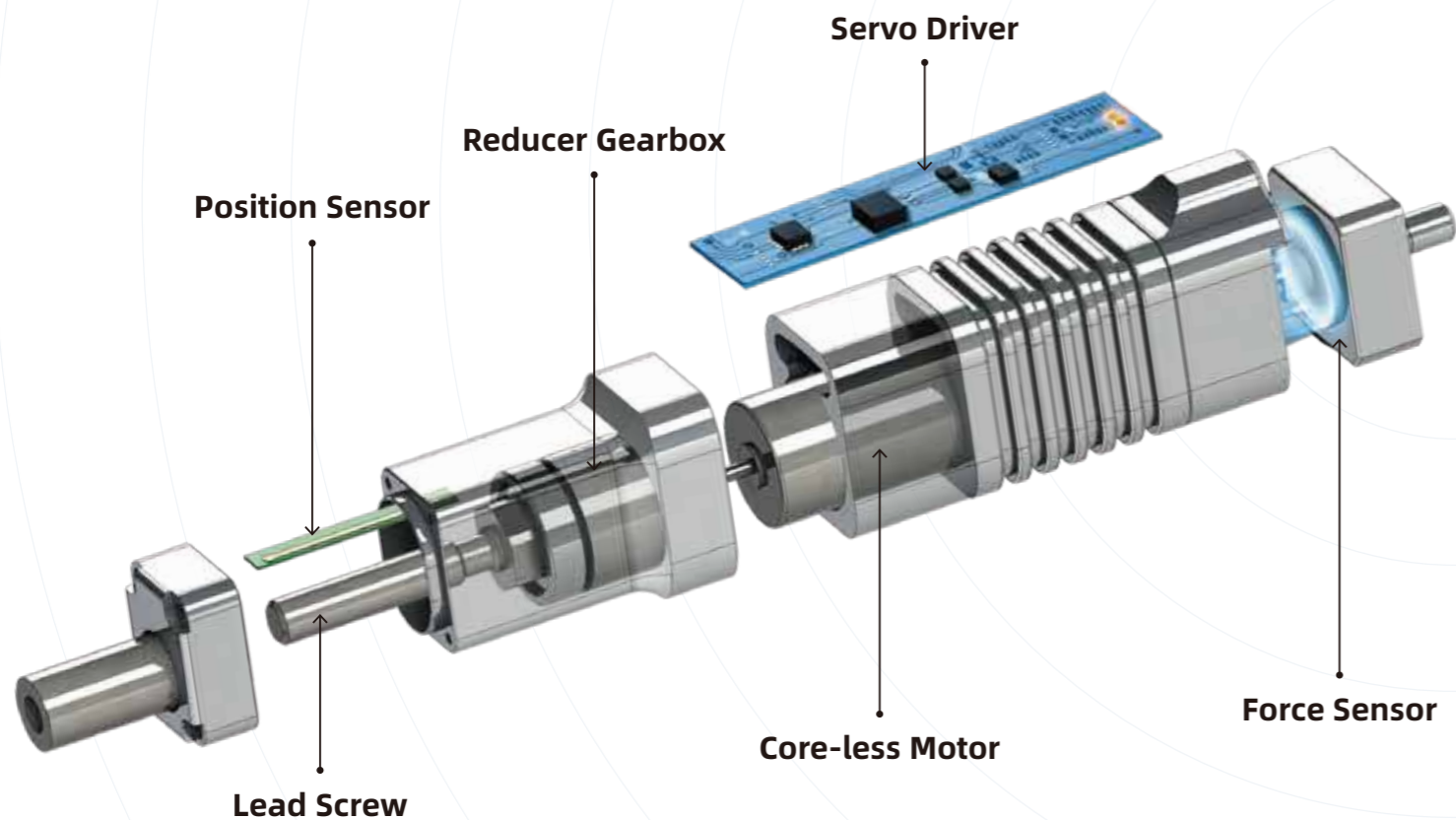

Controller Integrated

Force Control (Force Control Model)

Small Size

High Precision

High Power Density

## APPLICATIONS



### ROBOTIC



Humanoid Robot



Bionic Robot



Surgical Robot



Teleoperation Robot



Dexterous Hands



### BIOMEDICAL INSTRUMENT



Minimally Invasive Surgical Instrument



Aesthetic Medicine Instrument



In-Vitro Diagnostics



Rehabilitation Equipment / Exoskeleton



Laboratory Automation



### AUTOMATED INDUSTRY



New Energy



3C Electronic Equipment



Semiconductor Equipment



Optical Device



Auto Industry Equipment



3D Printing



Other Precise Instrument



### AEROSPACE



Aircraft



Manned Spacecraft



### EDUCATION AND SCIENTIFIC RESEARCH

# APPLICATIONS CASES



## NEW ENERGY

### Micro linear servo actuator achieve closed-loop coating adjustment

#### Features

The narrowest section of the actuator: 12mm  
 Repeatability :  $\pm 2\mu\text{m}$   
 The maximum load force: 400N

#### Advantages

The T-bar could be settled into the narrowest space of 12mm, and the coating adjustment can be more precisely, greatly improving the COV and high quality product rate. The minimum step is  $1\mu\text{m}$ , high precision real time closed-loop control. The large loading, adaptable to different viscosity slurries.



## HUMANOID ROBOT

### Micro linear servo actuator can be used for the joint of humanoid robot

#### Features

The small size actuator can be used as finger joints, with high power density and force control function.

#### Advantages

The actuator can be applied to single degree of freedom joints with small swing angles, such as dexterous hands, arms, legs, necks and waists of humanoid robots. The high integration construction simplify the robot structure, which helps to improve the flexibility and working ability.



## BIOMEDICAL INSTRUMENT

### Micro linear servo actuator improves minimally invasive surgical instruments

#### Features

The actuator is integrated with linear servo system, with features small size, high precision and force control.

#### Advantages

The actuator solves the problem of large size of medical equipment. It effectively reduces the difficulty and risk of operation with precise force and position control, which helps to shorten the treatment process and improves user experience and economic benefits.

# Micro Linear Servo Actuator

# Series Introduction

## LA Series

Tandem placement of motor and screw structure.

Advantages: Slender appearance, small cross-section, light weight.

## LAS Series

Parallel placement of motor and screw structure.

Advantages: Compact dimensions, light weight.

## LAF Series

Adding integrated force sensor on the LA series basis.

Enabling real time push rod force detection and control.

## LASF Series

Adding integrated force sensor on the LAS series basis.

Enabling real time push rod force detection and control.

## BLA Series

BLA Series Micro Linear Servo Actuator integrates brushless motor and planetary roller screw. The drive control system includes FOC control algorithm, with four closed-loop controls of current, speed, position and force output.

BLA series is mainly used in 3C automation, semiconductor and new energy industry, and is suitable for tooling fixtures, electric fixtures, wafer handling, circuit board welding testing, microfluidic valves. etc.





# LA10 Series

## Micro Linear Servo Actuator

### Model Instruction

Series	Speed Level	Mechanical Interface	Electronic Interface	Model code <b>LA10-021D</b>
LA10	02	1	D	
Stroke	02 03 07 09	1-Standard Interface 2-Ear Interface 3-Octagonal Interface	D-LVTTL Serial port P-PWM Serial port	

### Standard Parameters

Stroke	Weight	Operating Voltage	Repeatability	Operating Temperature Range	Quiescent Current	Peak Current	IP Level
10mm	21g	DC8V±10%	±0.02mm	-10°C~+60°C	0.02A	2A	IP40

### Speed Levels and Associated Parameters

Speed Level	Maximum Force	Locked-Rotor Force	Maximum Self-Locking Force	No-load Speed	Full Load Speed	No-Load Current
02	70N	100N	100N	18mm/s	8mm/s	0.2A
03	56N	80N	100N	36mm/s	16mm/s	0.24A
07	42N	60N	50N	50mm/s	21mm/s	0.5A
09	21N	30N	38N	70mm/s	36mm/s	0.5A



Standard Interface



Ear Interface



Octagonal Interface

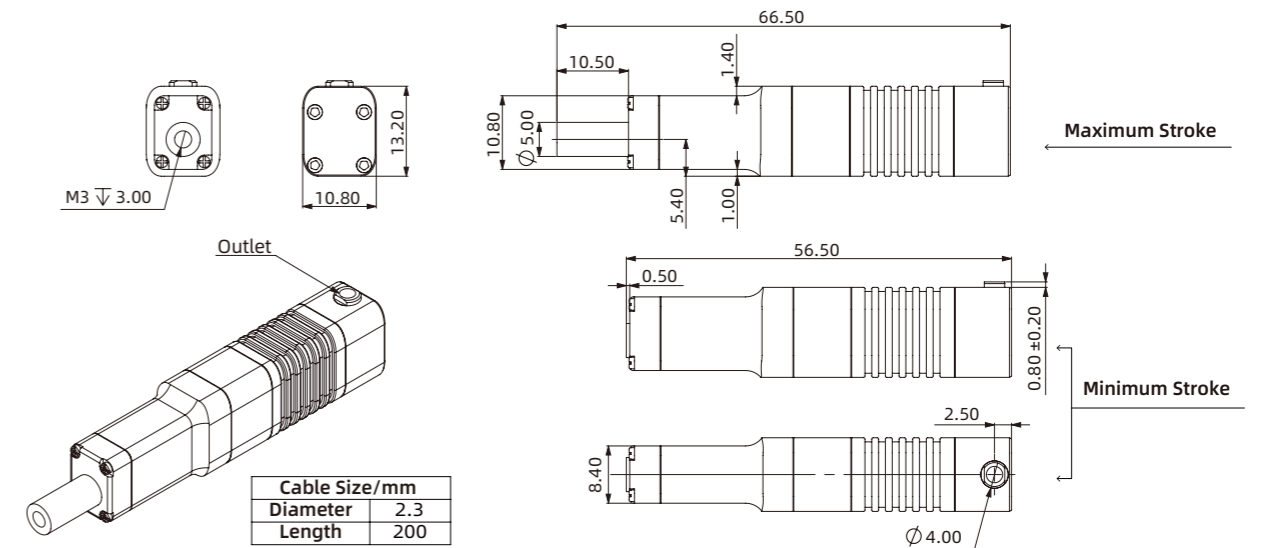

Standard Interface

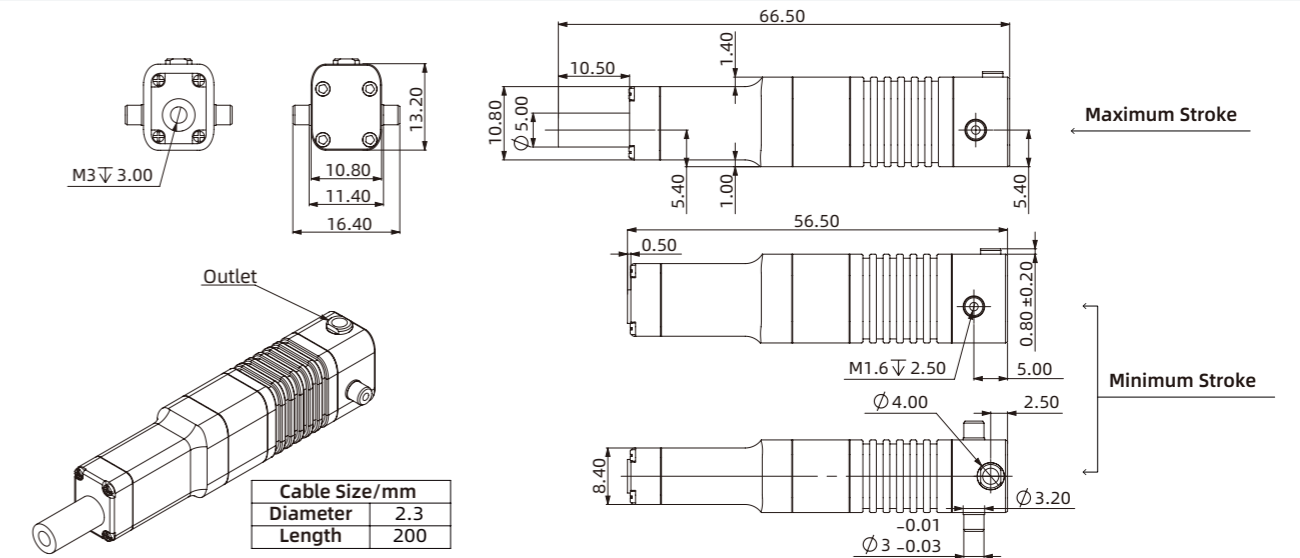

Ear Interface

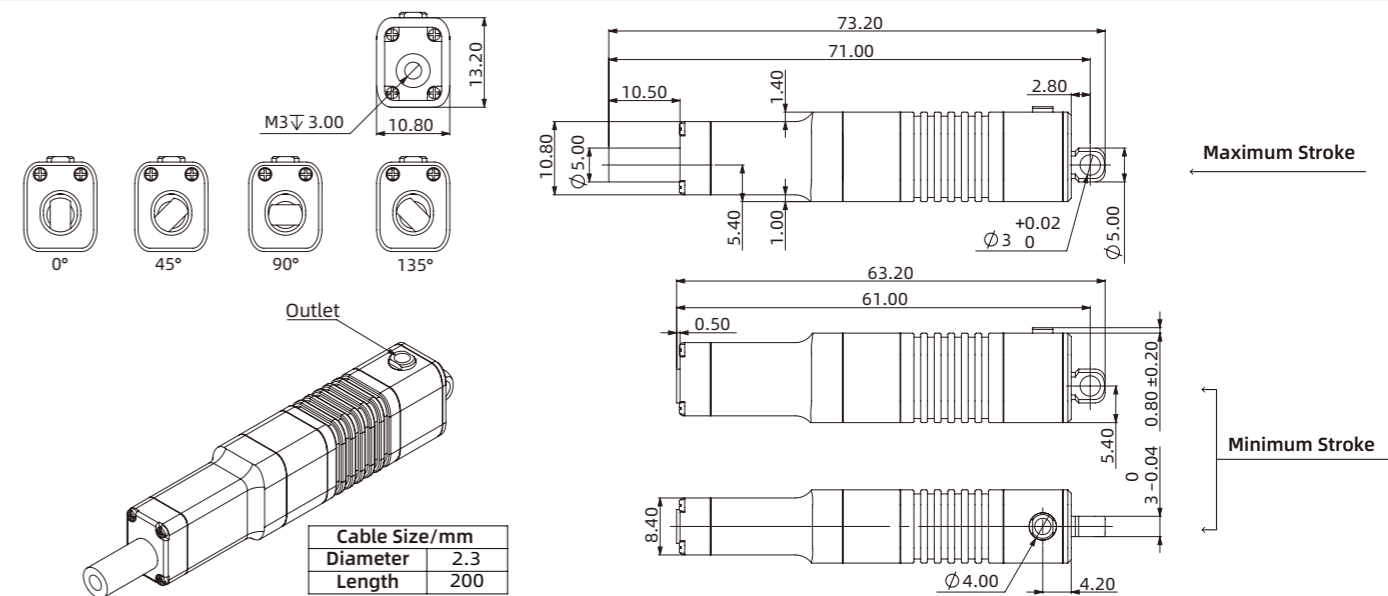

Octagonal Interface

# LA16 Series

## Micro Linear Servo Actuator

### Model Instruction

Series	Speed Level	Mechanical Interface	Electronic Interface	Model code <b>LA16-021D</b>
LA16	02	1	D	
Stroke	02 03 07 09	1-Standard Interface 2-Ear Interface 3-Octagonal Interface	D-LVTTL Serial port P-PWM Serial port	

### Standard Parameters

Stroke	Weight	Operating Voltage	Repeatability	Operating Temperature Range	Quiescent Current	Peak Current	IP Level
16mm	23g	DC8V±10%	±0.03mm	-10°C~+60°C	0.02A	2A	IP40

### Speed Levels and Associated Parameters

Speed Level	Maximum Force	Locked-Rotor Force	Maximum Self-Locking Force	No-load Speed	Full Load Speed	No-Load Current
02	70N	100N	100N	18mm/s	8mm/s	0.2A
03	56N	80N	100N	36mm/s	16mm/s	0.24A
07	42N	60N	50N	50mm/s	21mm/s	0.5A
09	21N	30N	38N	70mm/s	36mm/s	0.5A



Standard Interface



Ear Interface



Octagonal Interface

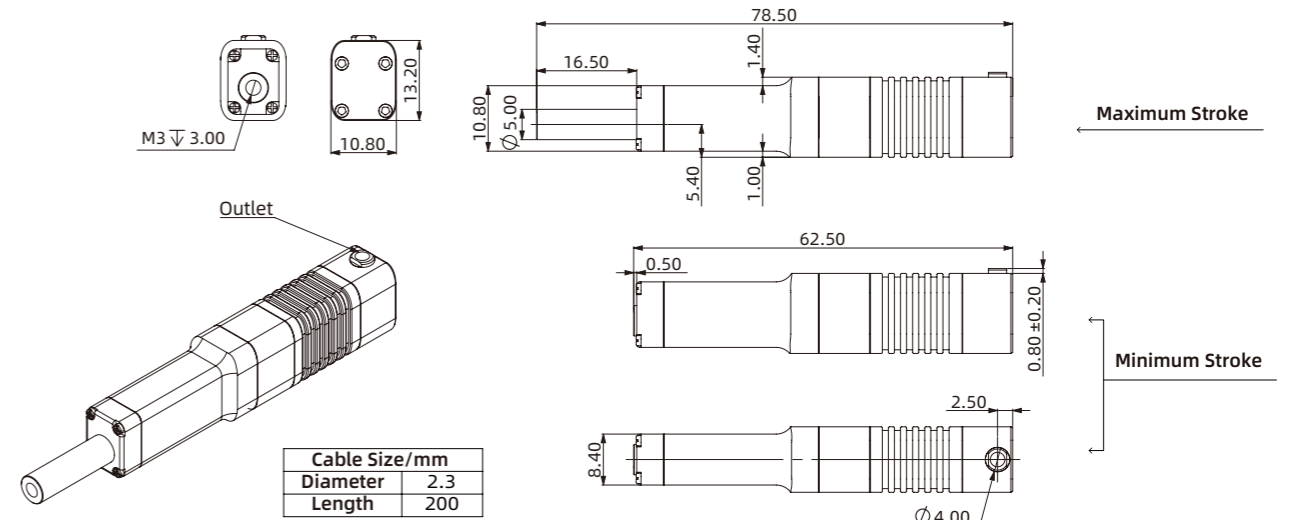

Standard Interface

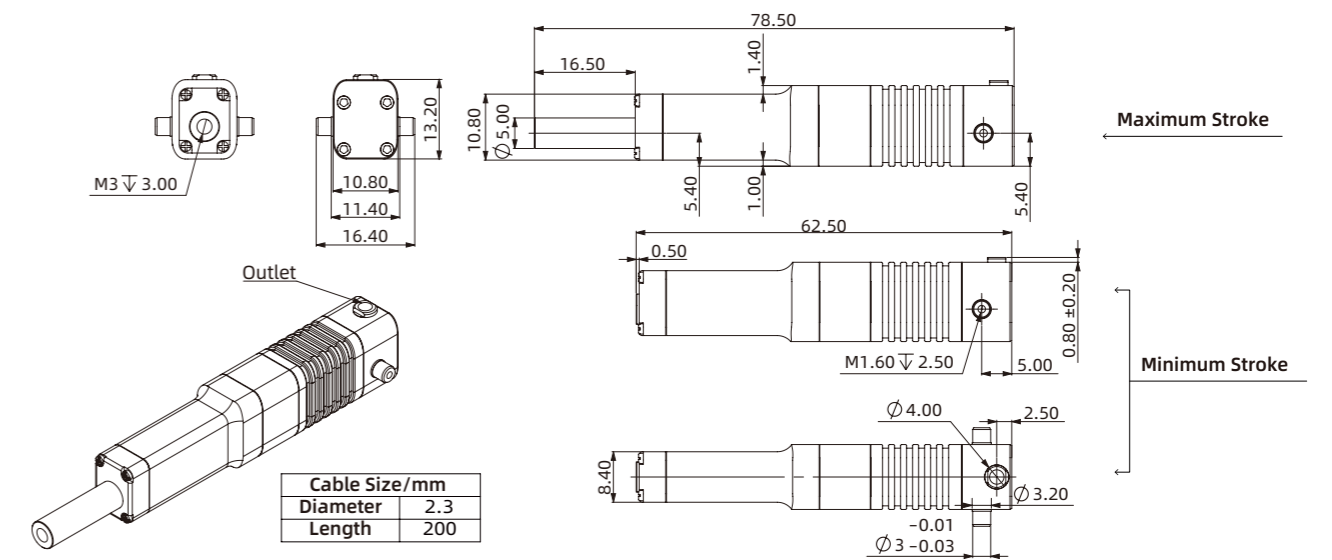

Ear Interface

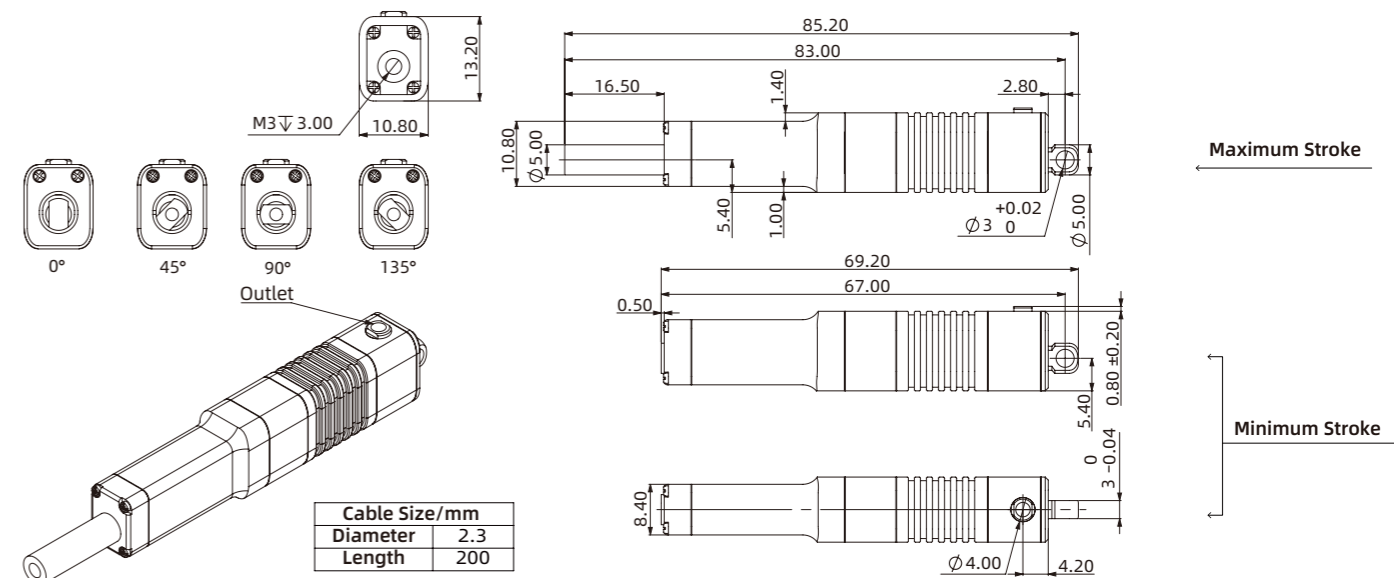

Octagonal Interface



# LA30 Series

## Micro Linear Servo Actuator

### Model Instruction

Series	Speed Level	Mechanical Interface	Electronic Interface	Model code <b>LA30-021D</b>
LA30	02	1	D	
Stroke	02	1-Standard Interface 2-Ear Interface 3-Octagonal Interface	D-LVTTL Serial port P-PWM Serial port	

### Standard Parameters

Stroke	Weight	Operating Voltage	Repeatability	Operating Temperature Range	Quiescent Current	Peak Current	IP level
30mm	30g	DC8V±10%	±0.06mm	-10°C~+60°C	0.02A	2A	IP40

### Speed Levels and Associated Parameters

Speed Level	Maximum Force	Locked-Rotor Force	Maximum Self-Locking Force	No-load Speed	Full Load Speed	No-Load Current
02	50N	80N	80N	17mm/s	8mm/s	0.3A



Standard Interface



Ear Interface



Octagonal Interface

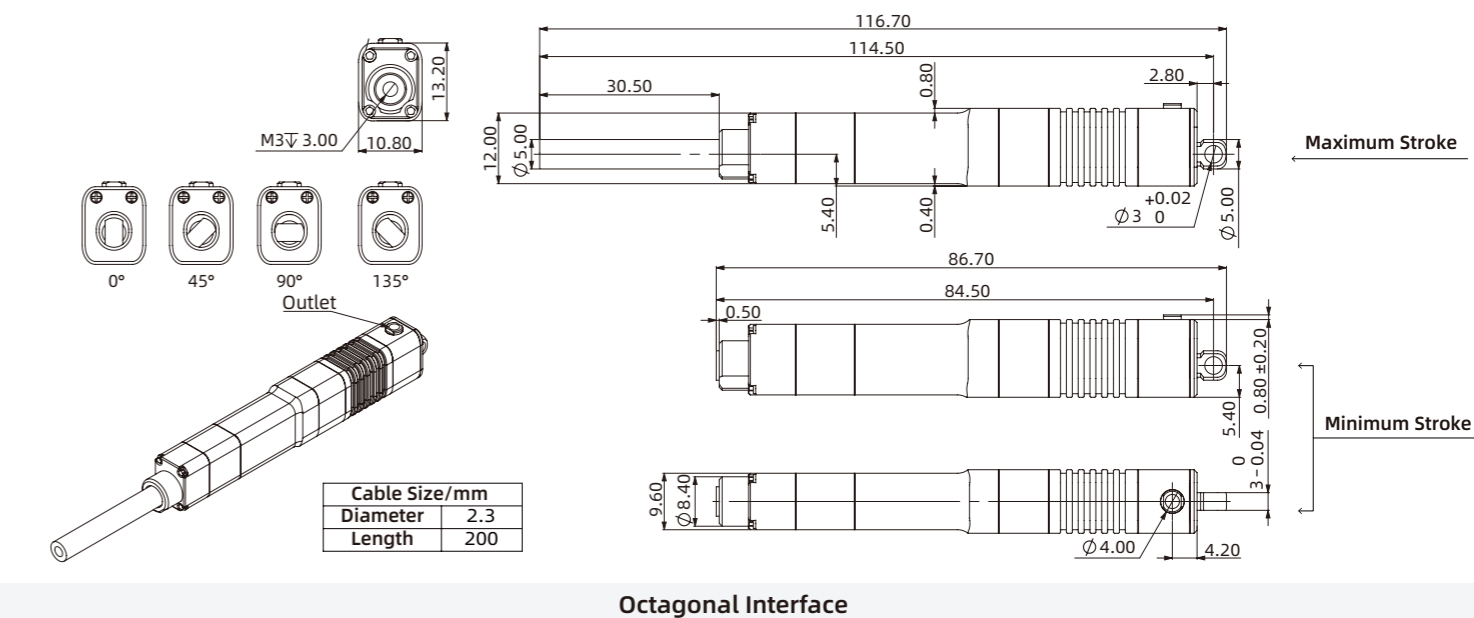
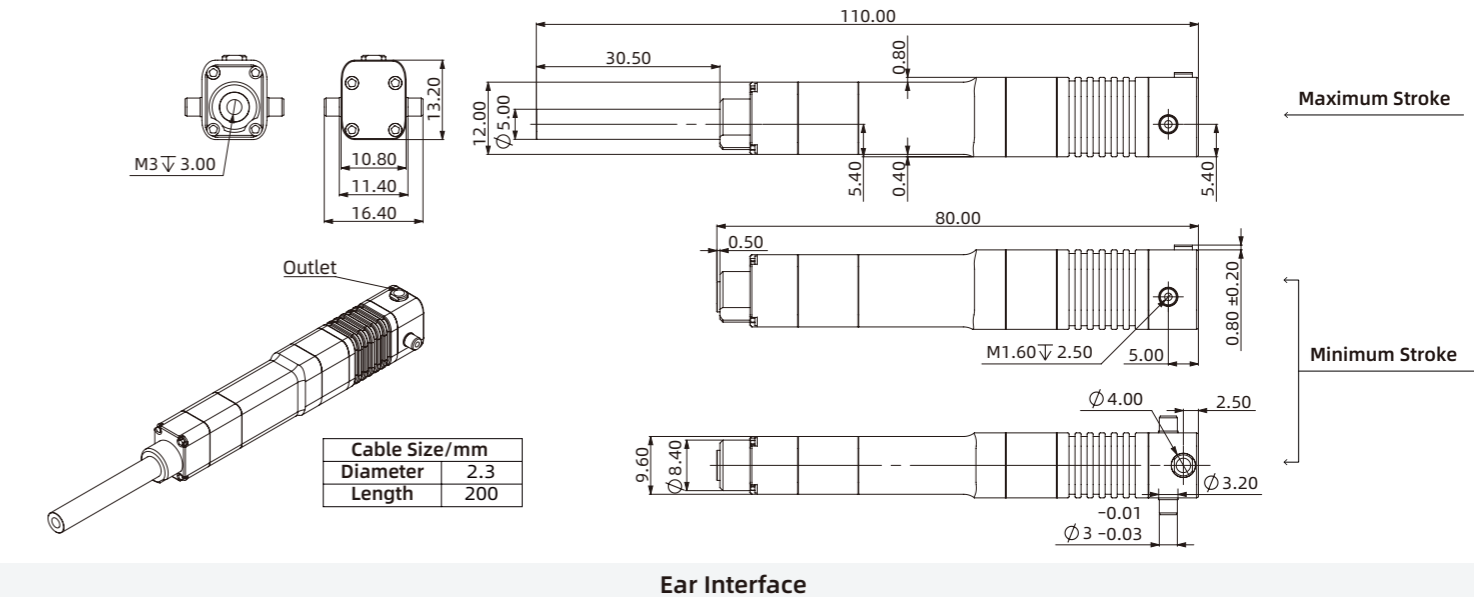
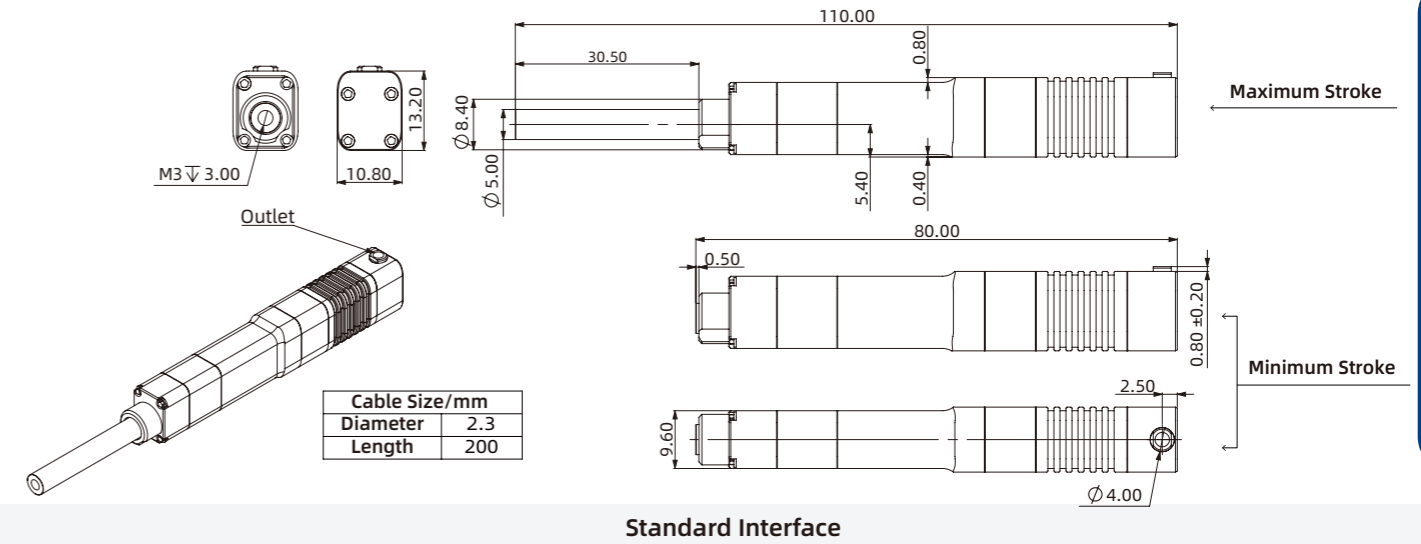

# LA50 Series

## Micro Linear Servo Actuator

### Model Instruction

Series	Speed Level	Mechanical Interface	Electronic Interface	Model code <b>LA50-021D</b>
LA50	02	1	D	
Stroke	02	1-Standard Interface 2-Ear Interface 3-Octagonal Interface	D-LVTTL Serial port P-PWM Serial port	

### Standard Parameters

Stroke	Weight	Operating Voltage	Repeatability	Operating Temperature Range	Quiescent Current	Peak Current	IP level
50mm	42g	DC8V±10%	±0.1mm	-10°C~+60°C	0.02A	2A	IP40

### Speed Levels and Associated Parameters

Speed Level	Maximum Force	Locked-Rotor Force	Maximum Self-Locking Force	No-load Speed	Full Load Speed	No-Load Current
02	50N	80N	80N	17mm/s	8mm/s	0.3A



Standard Interface



Ear Interface



Octagonal Interface

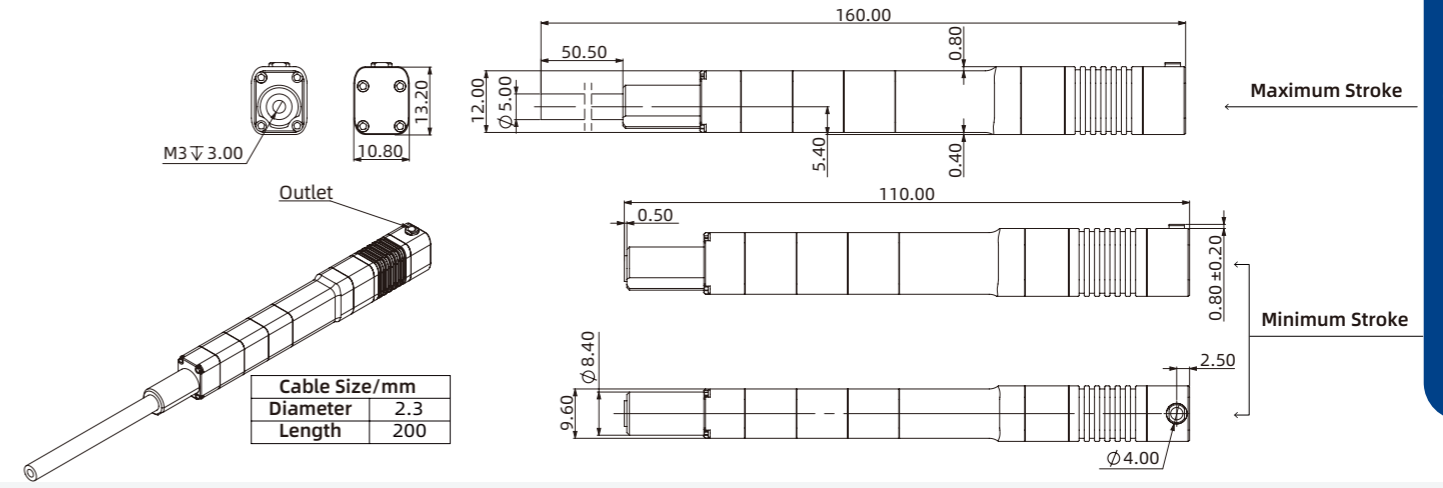

Standard Interface

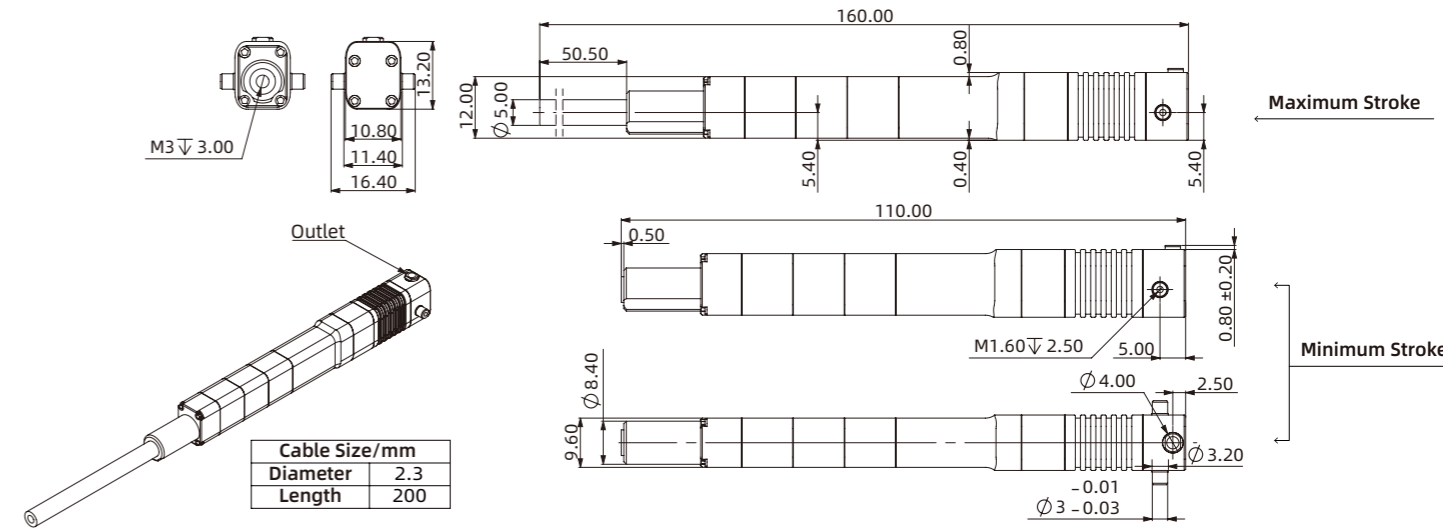

Ear Interface

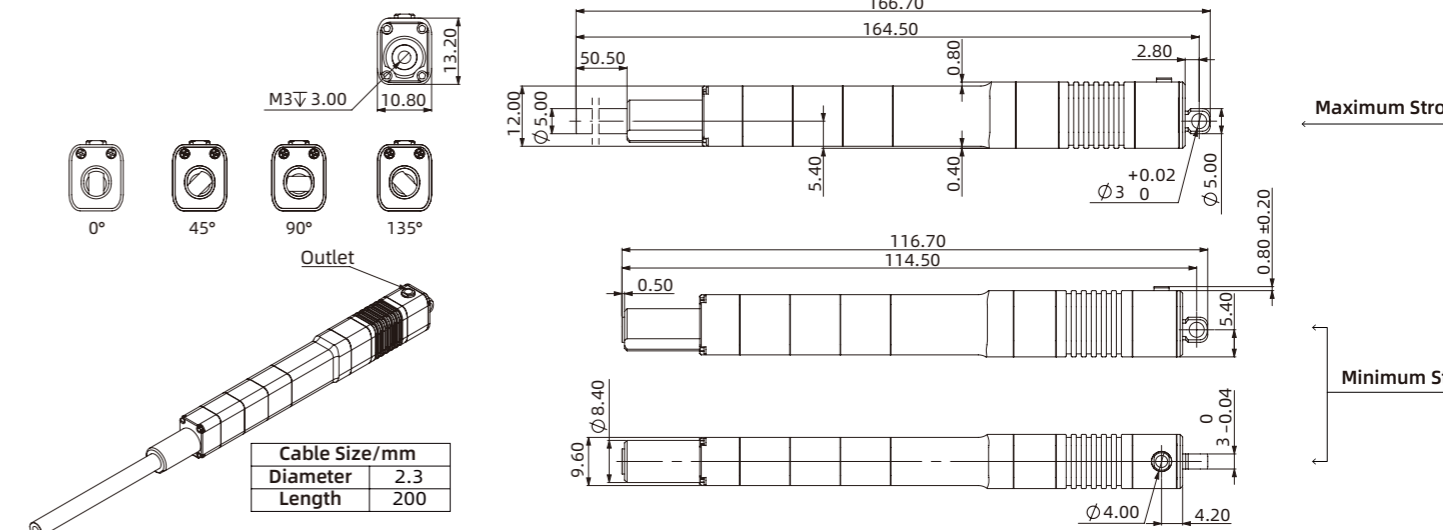

Octagonal Interface

# LAS10 Series

## Micro Linear Servo Actuator

### Model Instruction

Series	Speed Level	Mechanical Interface	Electronic Interface	Model code
LAS10	02	1	D	LAS10-021D
Stroke	02	1-Standard Interface	D-LVTTL Serial port	
	03	3-Octagonal Interface	P-PWM Serial port	
	06			
	08			
	10			

### Standard Parameters

Stroke	Weight	Operating Voltage	Repeatability	Operating Temperature Range	Quiescent Current	Peak Current	IP level
10mm	24g	DC8V±10%	±0.02mm	-10°C~+60°C	0.02A	2A	IP40

### Speed Levels and Associated Parameters

Speed Level	Maximum Force	Locked-Rotor Force	Maximum Self-Locking Force	No-load Speed	Full Load Speed	No-Load Current
02	105N	150N	150N	13mm/s	4mm/s	0.2A
03	56N	80N	150N	26mm/s	12mm/s	0.24A
06	49N	70N	50N	38mm/s	18mm/s	0.5A
08	35N	50N	38N	53mm/s	27mm/s	0.5A
10	31N	45N	30N	62mm/s	39mm/s	0.5A



Standard Interface



Octagonal Interface

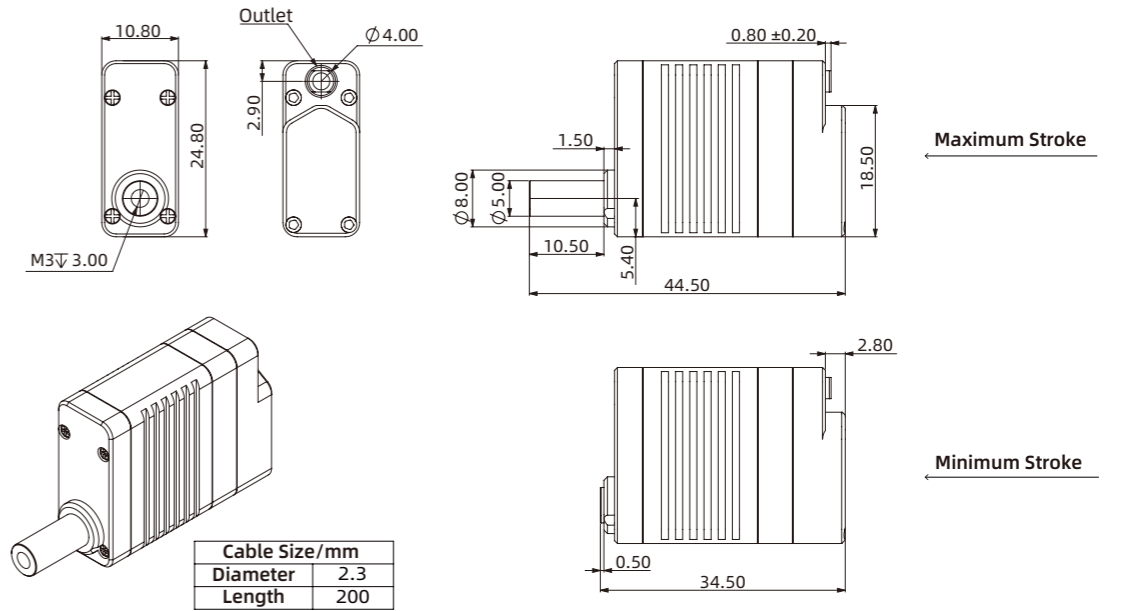

Standard Interface

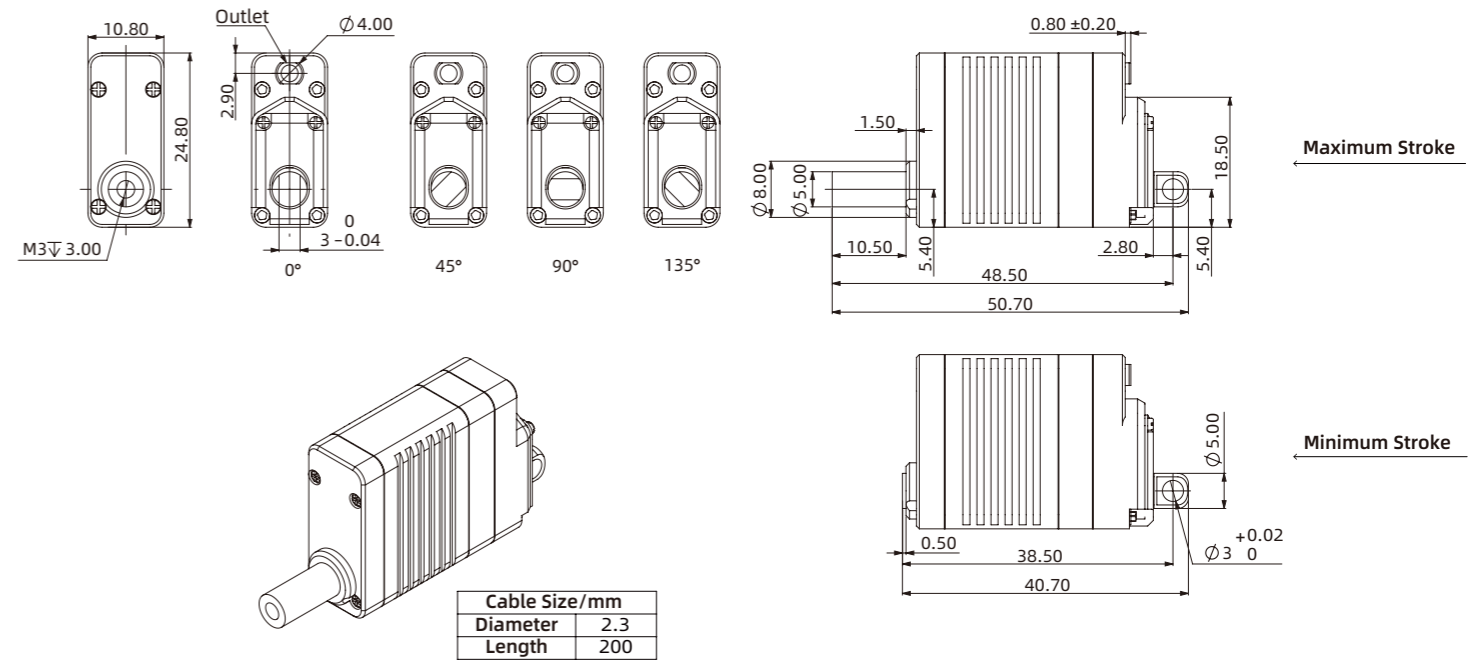



# LAS16 Series

## Micro Linear Servo Actuator

### Model Instruction

Series	Speed Level	Mechanical Interface	Electronic Interface	Model code
LAS16	02	1	D	LAS16-021D
Stroke	02 03 06 08 10	1-Standard Interface 3-Octagonal Interface	D-LVTTL Serial port P-PWM Serial port	

### Standard Parameters

Stroke	Weight	Operating Voltage	Repeatability	Operating Temperature Range	Quiescent Current	Peak Current	IP level
16mm	27g	DC8V±10%	±0.03mm	-10°C~+60°C	0.02A	2A	IP40

### Speed Levels and Associated Parameters

Speed Level	Maximum Force	Locked-Rotor Force	Maximum Self-Locking Force	No-load Speed	Full Load Speed	No-Load Current
02	105N	150N	150N	13mm/s	4mm/s	0.2A
03	56N	80N	150N	26mm/s	12mm/s	0.24A
06	49N	70N	50N	38mm/s	18mm/s	0.5A
08	35N	50N	38N	53mm/s	27mm/s	0.5A
10	31N	45N	30N	62mm/s	39mm/s	0.5A



Standard Interface



Octagonal Interface

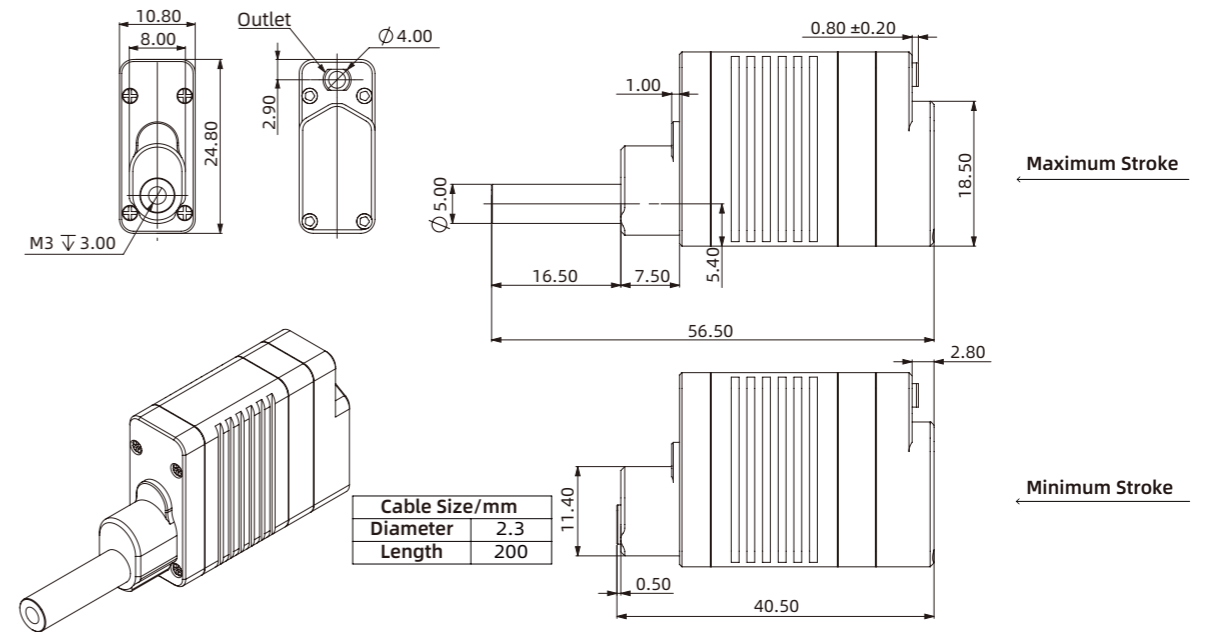

Standard Interface

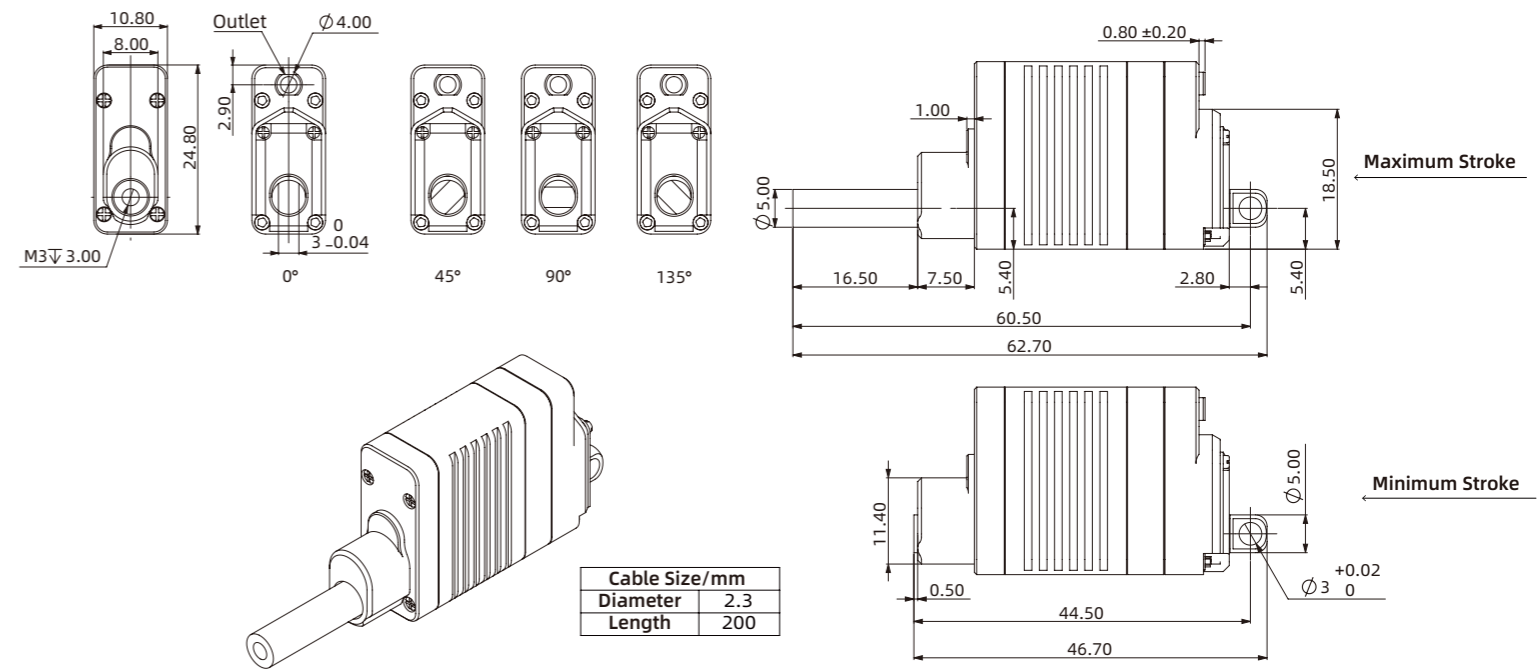

Octagonal Interface



# LAF10 Series

Micro Linear Servo Actuator

## Model Instruction

Series	Speed Level	Mechanical Interface	Electronic Interface	Model code
LAF10	02	4	D	LAF10-024D
Stroke	02 03 07 09	4-Spherical Plain Bearing	D-LVTTL Serial port	

## Standard Parameters

Stroke	Weight	Operating Voltage	Repeatability	Operating Temperature Range	Quiescent Current	Peak Current	Force Sensor Detection Range	Force Sensor Resolution	IP level
10mm	29g	DC8V±10%	±0.02mm	-10°C~+60°C	0.05A	2A	-100N~+100N	1N	IP40

## Speed Levels and Associated Parameters

Speed Level	Maximum Force	Locked-Rotor Force	Maximum Self-Locking Force	No-load Speed	Full Load Speed	No-Load Current
02	70N	100N	100N	18mm/s	8mm/s	0.23A
03	56N	80N	100N	36mm/s	16mm/s	0.27A
07	42N	60N	50N	50mm/s	21mm/s	0.53A
09	21N	30N	38N	70mm/s	36mm/s	0.53A

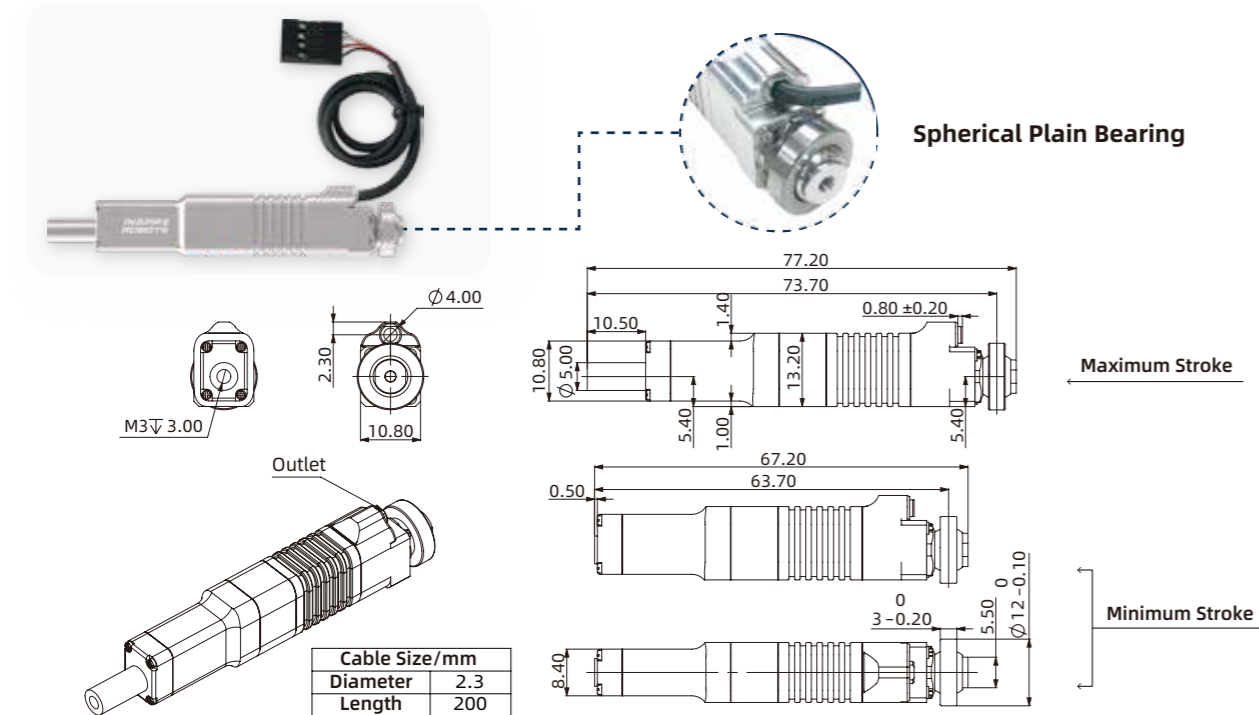

Spherical Plain Bearing Interface

# LAF16 Series

Micro Linear Servo Actuator

## Model Instruction

Series	Speed Level	Mechanical Interface	Electronic Interface	Model code
LAF16	02	4	D	LAF16-024D
Stroke	02 03 07 09	4-Spherical Plain Bearing	D-LVTTL Serial port	

## Standard Parameters

Stroke	Weight	Operating Voltage	Repeatability	Operating Temperature Range	Quiescent Current	Peak Current	Force Sensor Detection Range	Force Sensor Resolution	IP level
16mm	33g	DC8V±10%	±0.03mm	-10°C~+60°C	0.05A	2A	-100N~+100N	1N	IP40

## Speed Levels and Associated Parameters

Speed Level	Maximum Force	Locked-Rotor Force	Maximum Self-Locking Force	No-load Speed	Full Load Speed	No-Load Current
02	70N	100N	100N	18mm/s	8mm/s	0.23A
03	56N	80N	100N	36mm/s	16mm/s	0.27A
07	42N	60N	50N	50mm/s	21mm/s	0.53A
09	21N	30N	38N	70mm/s	36mm/s	0.53A

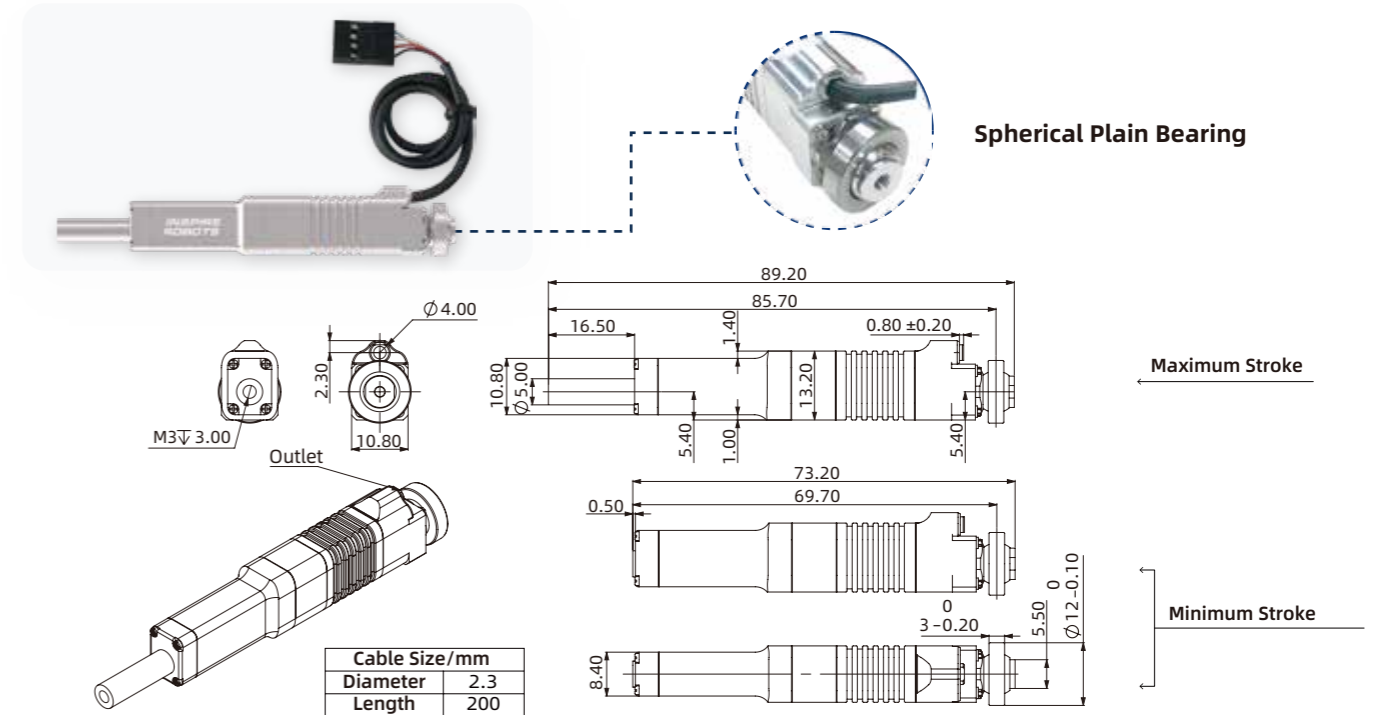

Spherical Plain Bearing Interface



# LAF30 Series

Micro Linear Servo Actuator

### Model Instruction

Series	Speed Level	Mechanical Interface	Electronic Interface	Model code
LAF30	02	4	D	LAF30-024D
Stroke	02	4-Spherical Plain Bearing	D-LVTTL Serial port	

### Standard Parameters

Stroke	Weight	Operating Voltage	Repeatability	Operating Temperature Range	Quiescent Current	Peak Current	Force Sensor Detection Range	Force Sensor Resolution	IP level
30mm	38g	DC8V±10%	±0.06mm	-10°C~+60°C	0.05A	2A	-100N~+100N	1N	IP40

### Speed Levels and Associated Parameters

Speed Level	Maximum Force	Locked-Rotor Force	Maximum Self-Locking Force	No-load Speed	Full Load Speed	No-Load Current
02	50N	80N	80N	17mm/s	8mm/s	0.3A

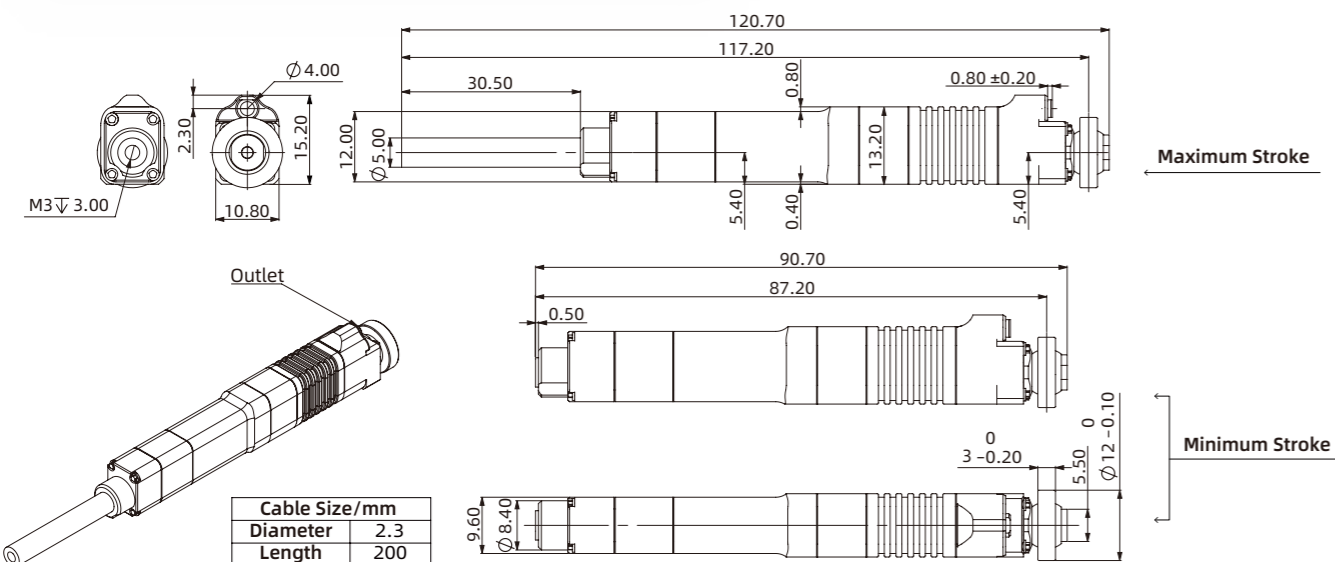
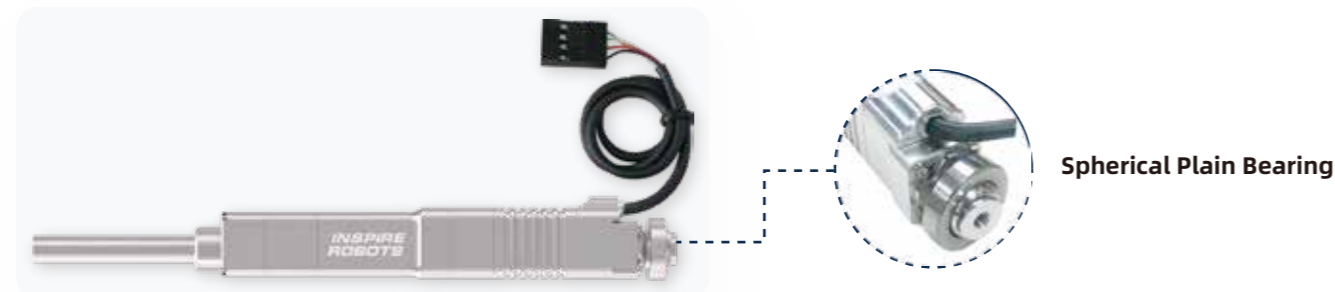

Spherical Plain Bearing Interface

# LAF50 Series

Micro Linear Servo Actuator

### Model Instruction

Series	Speed Level	Mechanical Interface	Electronic Interface	Model code
LAF50	02	4	D	LAF50-024D
Stroke	02	4-Spherical Plain Bearing	D-LVTTL Serial port	

### Standard Parameters

Stroke	Weight	Operating Voltage	Repeatability	Operating Temperature Range	Quiescent Current	Peak Current	Force Sensor Detection Range	Force Sensor Resolution	IP level
50mm	50g	DC8V±10%	±0.1mm	-10°C~+60°C	0.05A	2A	-100N~+100N	1N	IP40

### Speed Levels and Associated Parameters

Speed Level	Maximum Force	Locked-Rotor Force	Maximum Self-Locking Force	No-load Speed	Full Load Speed	No-Load Current
02	50N	80N	80N	17mm/s	8mm/s	0.3A

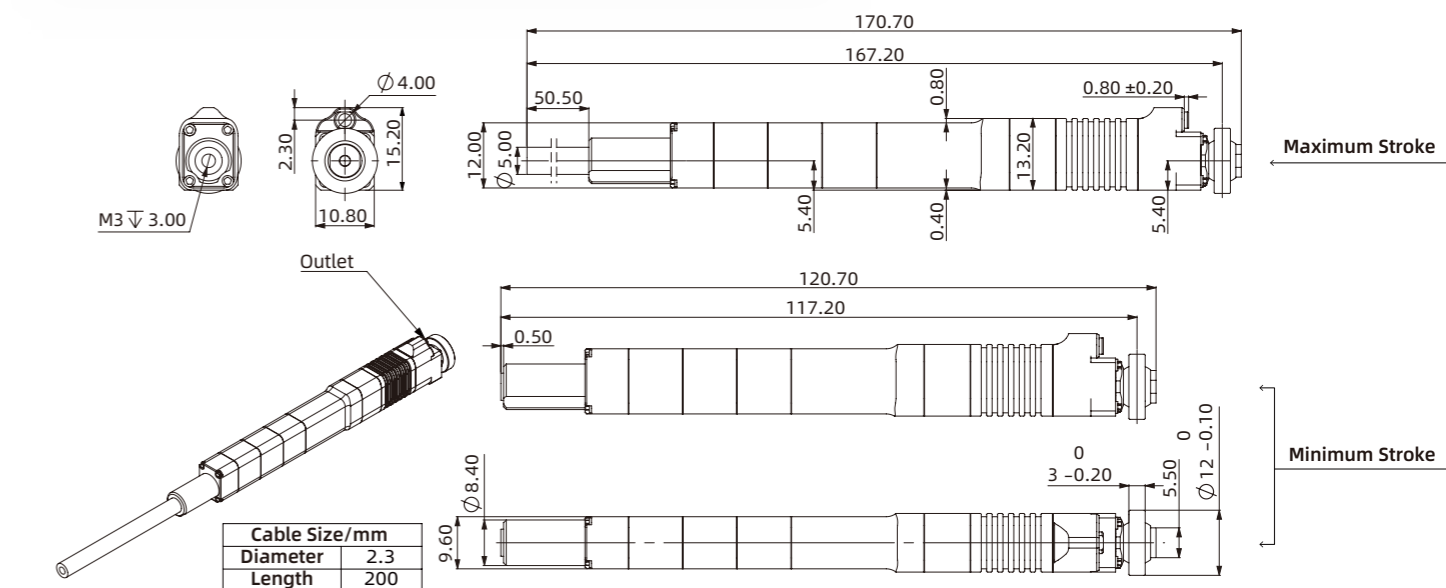
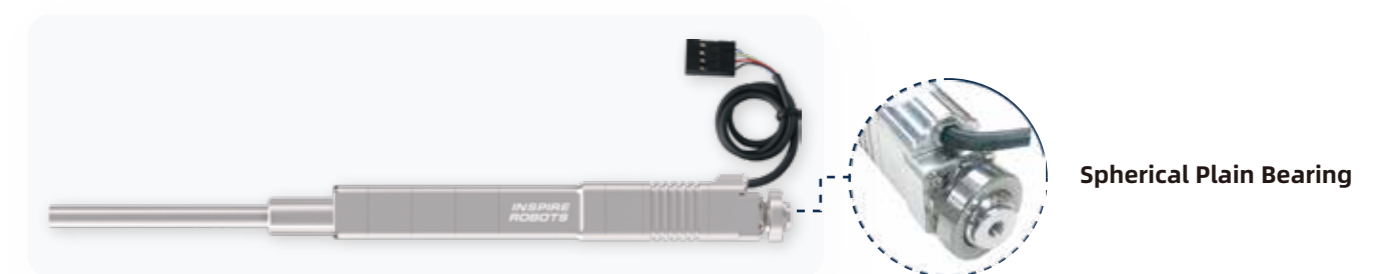

Spherical Plain Bearing Interface

# LASF10 Series

Micro Linear Servo Actuator

## Model Instruction

Series	Speed Level	Mechanical Interface	Electronic Interface	Model code
LASF10	02	4	D	LASF10-024D
Stroke	02 03 06 08 10	4-Spherical Plain Bearing	D-LVTTL Serial port	

## Standard Parameters

Stroke	Weight	Operating Voltage	Repeatability	Operating Temperature Range	Quiescent Current	Peak Current	Force Sensor Detection Range	Force Sensor Resolution	IP level
10mm	32g	DC8V±10%	±0.02mm	-10°C~+60°C	0.05A	2A	-100N~+100N	1N	IP40

## Speed Levels and Associated Parameters

Speed Level	Maximum Force	Locked-Rotor Force	Maximum Self-Locking Force	No-load Speed	Full Load Speed	No-Load Current
02	105N	150N	150N	13mm/s	4mm/s	0.53A
03	56N	80N	150N	26mm/s	12mm/s	0.63A
06	49N	70N	50N	38mm/s	18mm/s	0.73A
08	35N	50N	38N	53mm/s	27mm/s	0.73A
10	31N	45N	30N	62mm/s	39mm/s	0.73A

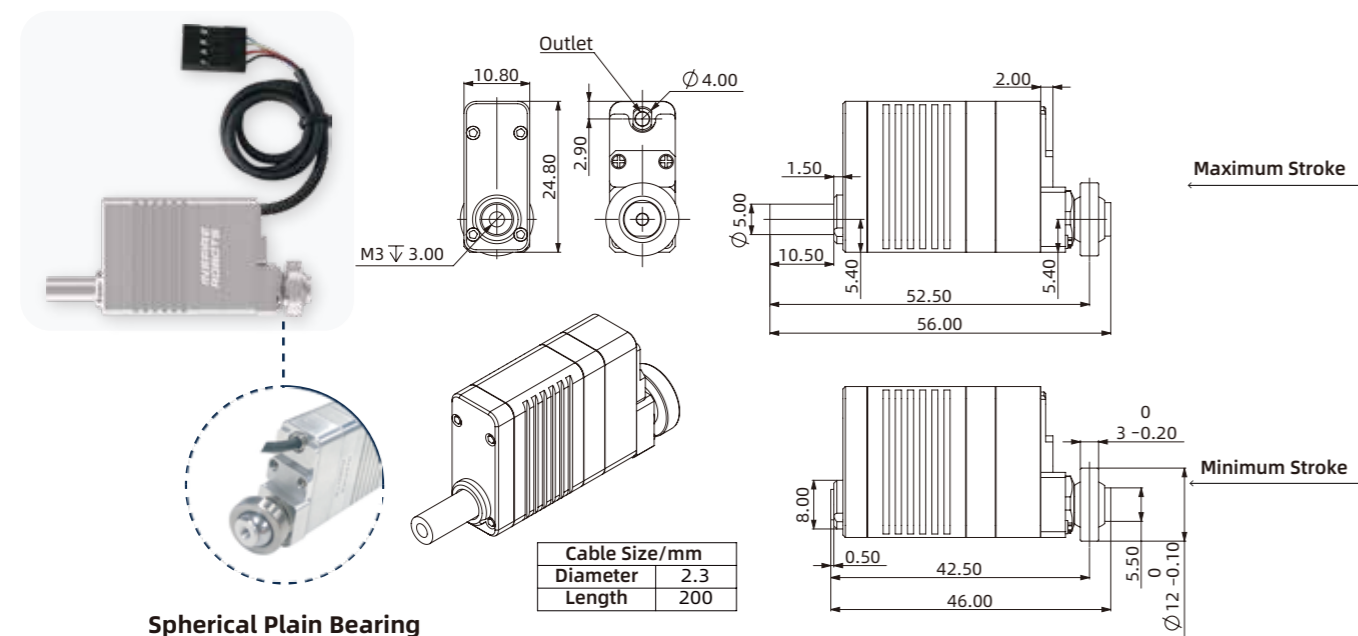

Spherical Plain Bearing Interface

# LASF16 Series

Micro Linear Servo Actuator

## Model Instruction

Series	Speed Level	Mechanical Interface	Electronic Interface	Model code
LASF16	02	4	D	LASF16-024D
Stroke	02 03 06 08 10	4-Spherical Plain Bearing	D-LVTTL Serial port	

## Standard Parameters

Stroke	Weight	Operating Voltage	Repeatability	Operating Temperature Range	Quiescent Current	Peak Current	Force Sensor Detection Range	Force Sensor Resolution	IP level
16mm	36g	DC8V±10%	±0.03mm	-10°C~+60°C	0.05A	2A	-100N~+100N	1N	IP40

## Speed Levels and Associated Parameters

Speed Level	Maximum Force	Locked-Rotor Force	Maximum Self-Locking Force	No-load Speed	Full Load Speed	No-Load Current
02	105N	150N	150N	13mm/s	4mm/s	0.53A
03	56N	80N	150N	26mm/s	12mm/s	0.63A
06	49N	70N	50N	38mm/s	18mm/s	0.73A
08	35N	50N	38N	53mm/s	27mm/s	0.73A
10	31N	45N	30N	62mm/s	39mm/s	0.73A

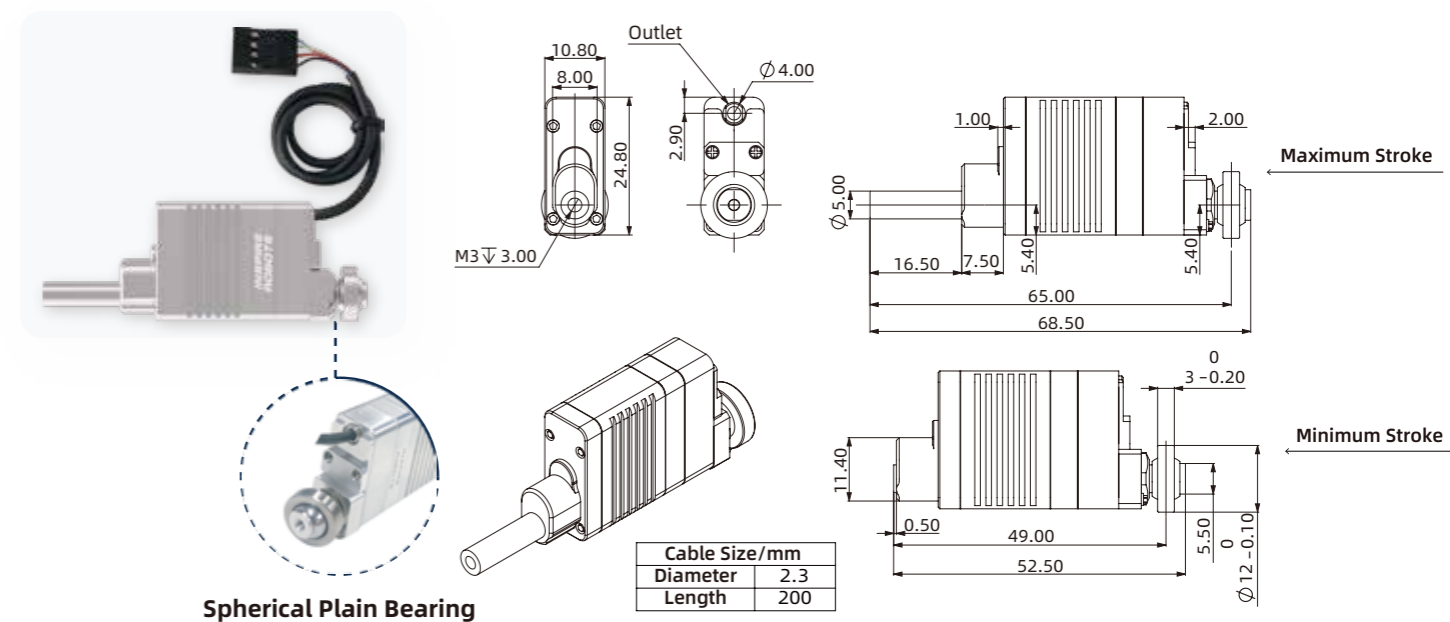

Spherical Plain Bearing Interface

# LASF30 Series

Micro Linear Servo Actuator

## Model Instruction

Series	Speed Level	Mechanical Interface	Electronic Interface	Model code
LASF30	02	4	D	LASF30-024D
Stroke	02	4-Spherical Plain Bearing	D-LVTTL Serial port	

## Standard Parameters

Stroke	Weight	Operating Voltage	Repeatability	Operating Temperature Range	Quiescent Current	Peak Current	Force Sensor Detection Range	Force Sensor Resolution	IP level
30mm	44g	DC8V±10%	±0.06mm	-10°C~+60°C	0.05A	2A	-100N~+100N	1N	IP40

## Speed Levels and Associated Parameters

Speed Level	Maximum Force	Locked-Rotor Force	Maximum Self-Locking Force	No-load Speed	Full Load Speed	No-Load Current
02	80N	110N	110N	13mm/s	6mm/s	0.3A

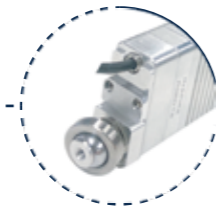

Spherical Plain Bearing

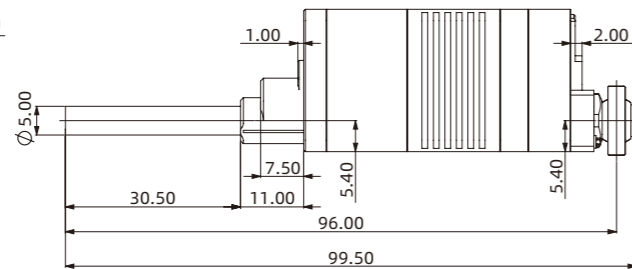
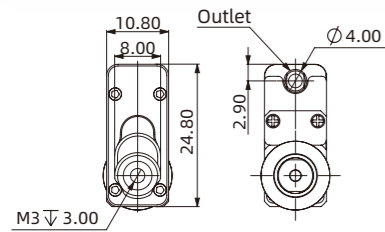

Maximum Stroke

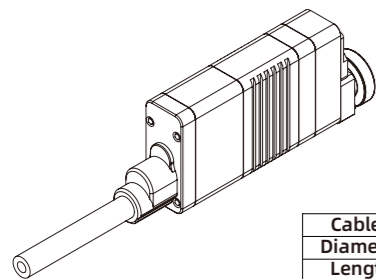

Cable Size/mm	
Diameter	2.3
Length	200

Spherical Plain Bearing Interface

Minimum Stroke

## Standard Parameters

Stroke	Weight	Operating Voltage	Repeatability	Operating Temperature Range	Quiescent Current	Peak Current	IP level
5mm	160g	DC12V±10%	± 0.002mm	-10°C~+60°C	55mA	1.4A	IP40

## Associated Parameters

Maximum Force	Locked-Rotor Force	Maximum Self-Locking Force	No-load Speed	Full Load Speed	No-Load Current	Communication interface	Motor
250N	300N	150N	2.4mm/s	2mm/s	200mA	RS485	Coreless Brushless DC Motors

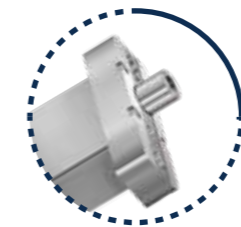

Flange Interface

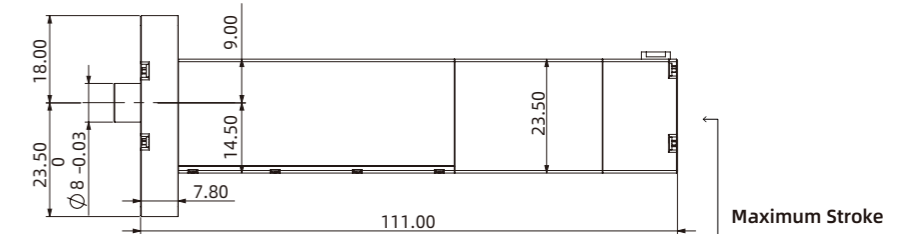
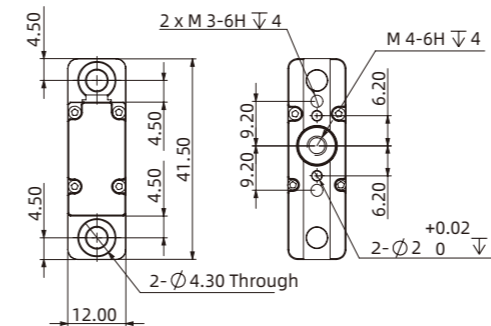

Maximum Stroke

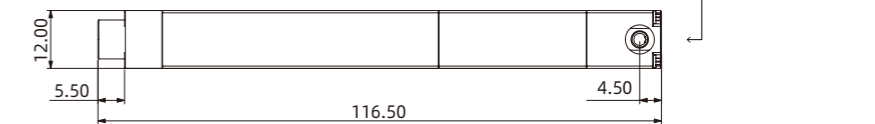

Minimum Stroke

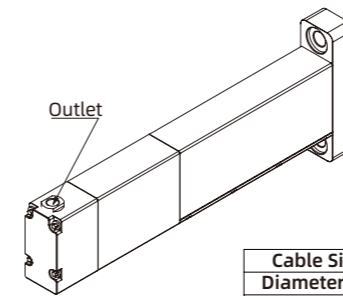

Cable Size/mm	
Diameter	3
Length	400

Flange Interface



# BLAS10-C152

## Micro Linear Servo Actuator

### Standard Parameters

Stroke	Weight	Operating Voltage	Repeatability	Operating Temperature Range	Quiescent Current	Peak Current	IP level
10mm	87g	DC12V±10%	±0.01mm	-10°C~+60°C	50mA	2A	IP40

### Associated Parameters

Maximum Force	Locked-Rotor Force	Maximum Self-Locking Force	No-load Speed	Full Load Speed	No-Load Current	Communication interface	Motor
150N	200N	70N	8mm/s	5mm/s	400mA	RS485	Coreless Brushless DC Motors

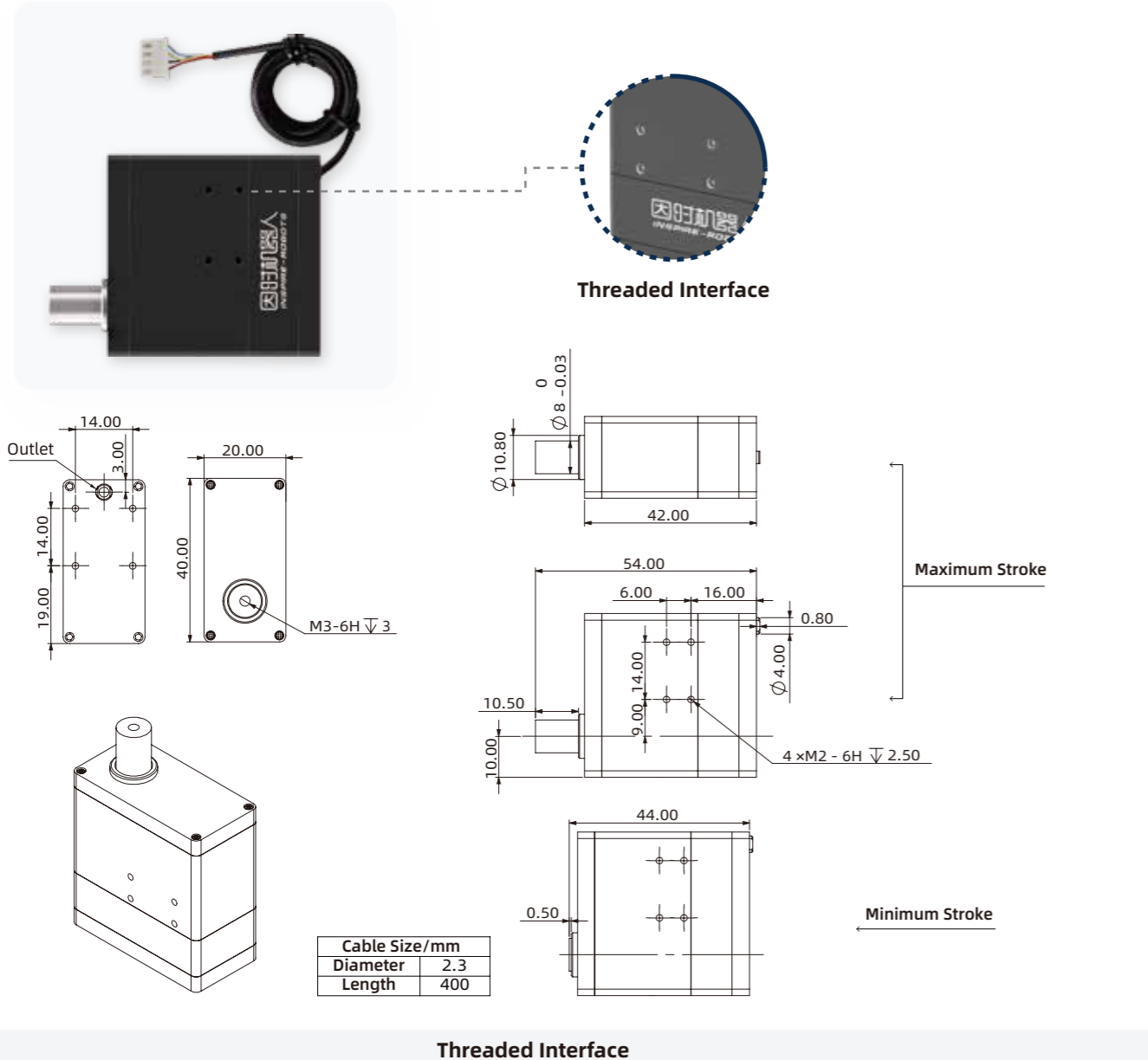

# BLASF10-C142

## Micro Linear Servo Actuator

### Standard Parameters

Stroke	Weight	Operating Voltage	Repeatability	Operating Temperature Range	Quiescent Current	Peak Current	Force Sensor Detection Range	Force Sensor Resolution	IP level
10mm	93g	DC12V±10%	±0.01mm	-10°C~+60°C	65mA	2A	-200N~+200N	1N	IP40

### Associated Parameters

Maximum Force	Locked-Rotor Force	Maximum Self-Locking Force	No-load Speed	Full Load Speed	No-Load Current	Communication interface	Motor
150N	200N	70N	8mm/s	5mm/s	400mA	RS485	Coreless Brushless DC Motors

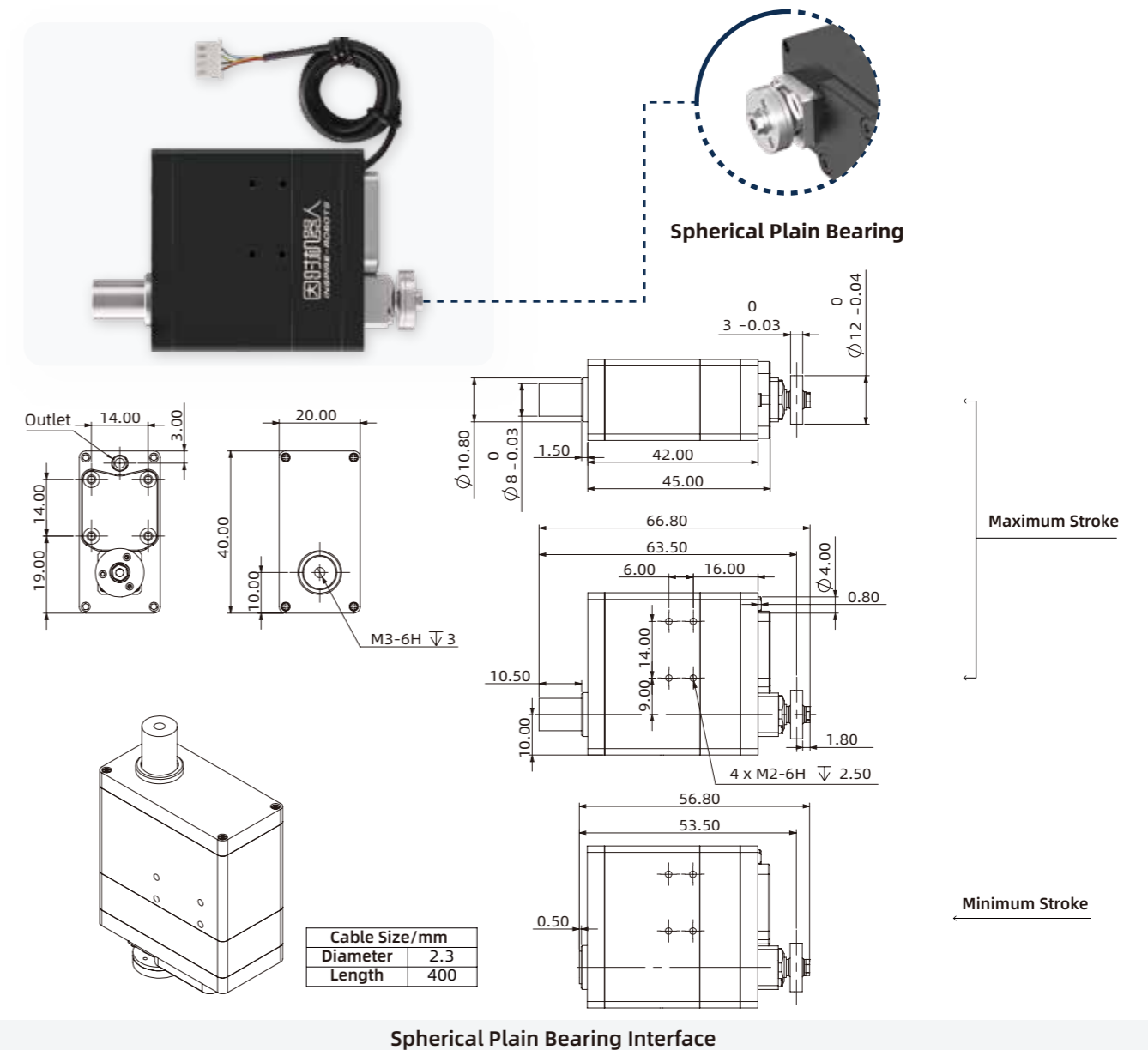

# BLAC30-C132

## Micro Linear Servo Actuator

### Standard Parameters

Stroke	Weight	Operating Voltage	Repeatability	Operating Temperature Range	Quiescent Current	Peak Current	IP level
30mm	113g	DC12V±10%	±0.01mm	-10°C~+60°C	50mA	2A	IP40

### Associated Parameters

Maximum Force	Locked-Rotor Force	Maximum Self-Locking Force	No-load Speed	Full Load Speed	No-Load Current	Communication interface	Motor
120N	150N	40N	32mm/s	16mm/s	600mA	RS485	Coreless Brushless DC Motors

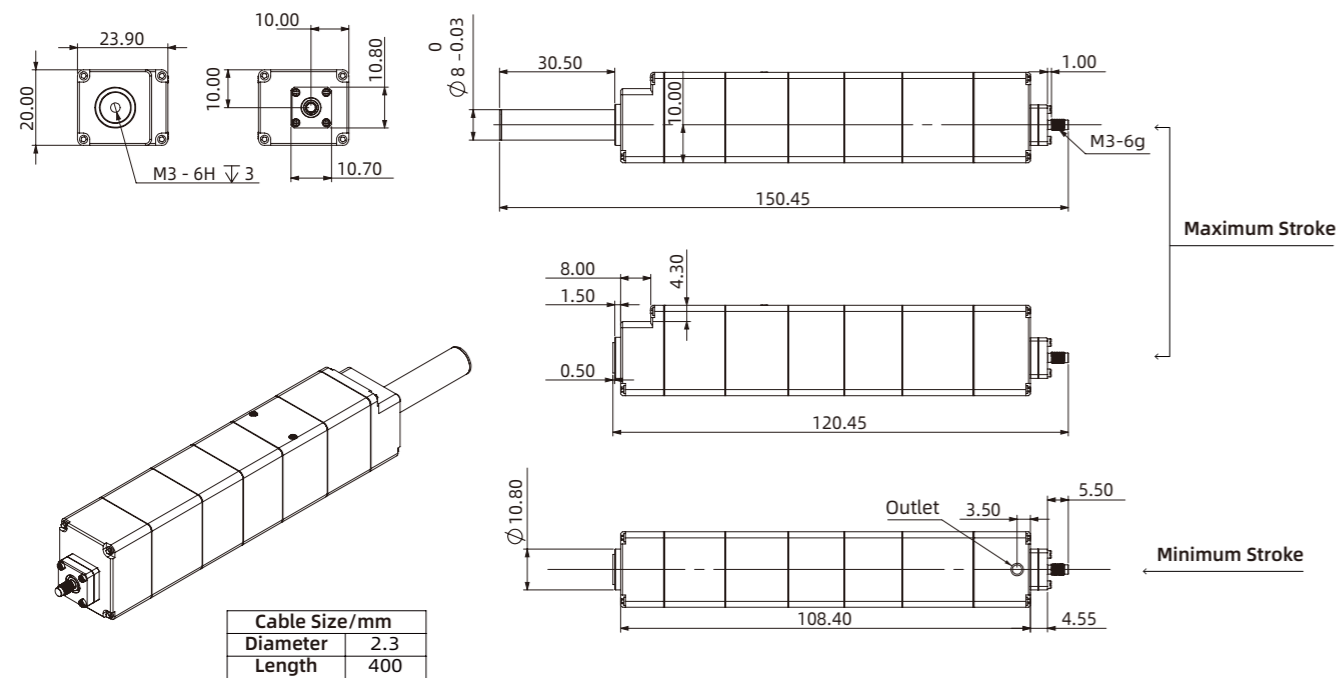
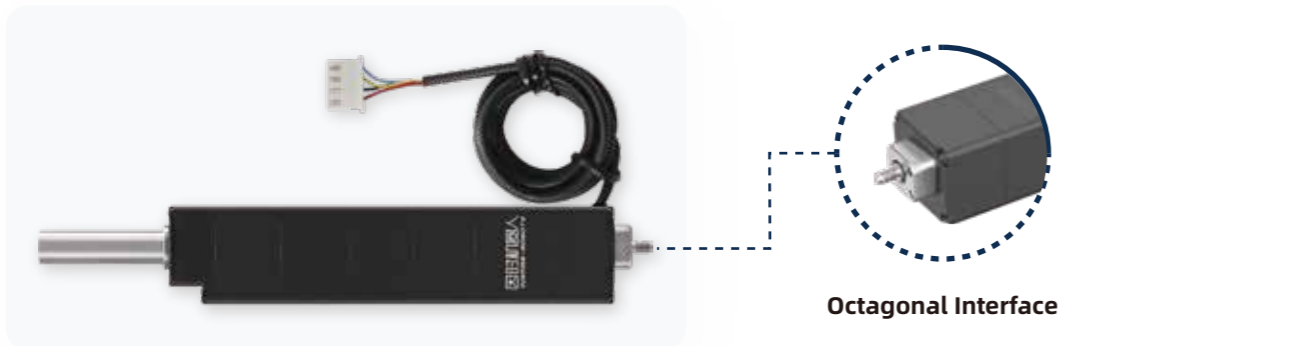

**Octagonal Interface**

# BLACF30-C142

## Micro Linear Servo Actuator

### Standard Parameters

Stroke	Weight	Operating Voltage	Repeatability	Operating Temperature Range	Quiescent Current	Peak Current	Force Sensor Detection Range	Force Sensor Resolution	IP level
30mm	112g	DC12V±10%	±0.01mm	-10°C~+60°C	65mA	2A	-200N ~+200N	1N	IP40

### Associated Parameters

Maximum Force	Locked-Rotor Force	Maximum Self-Locking Force	No-load Speed	Full Load Speed	No-Load Current	Communication interface	Motor
120N	150N	40N	32mm/s	16mm/s	600mA	RS485	Coreless Brushless DC Motors

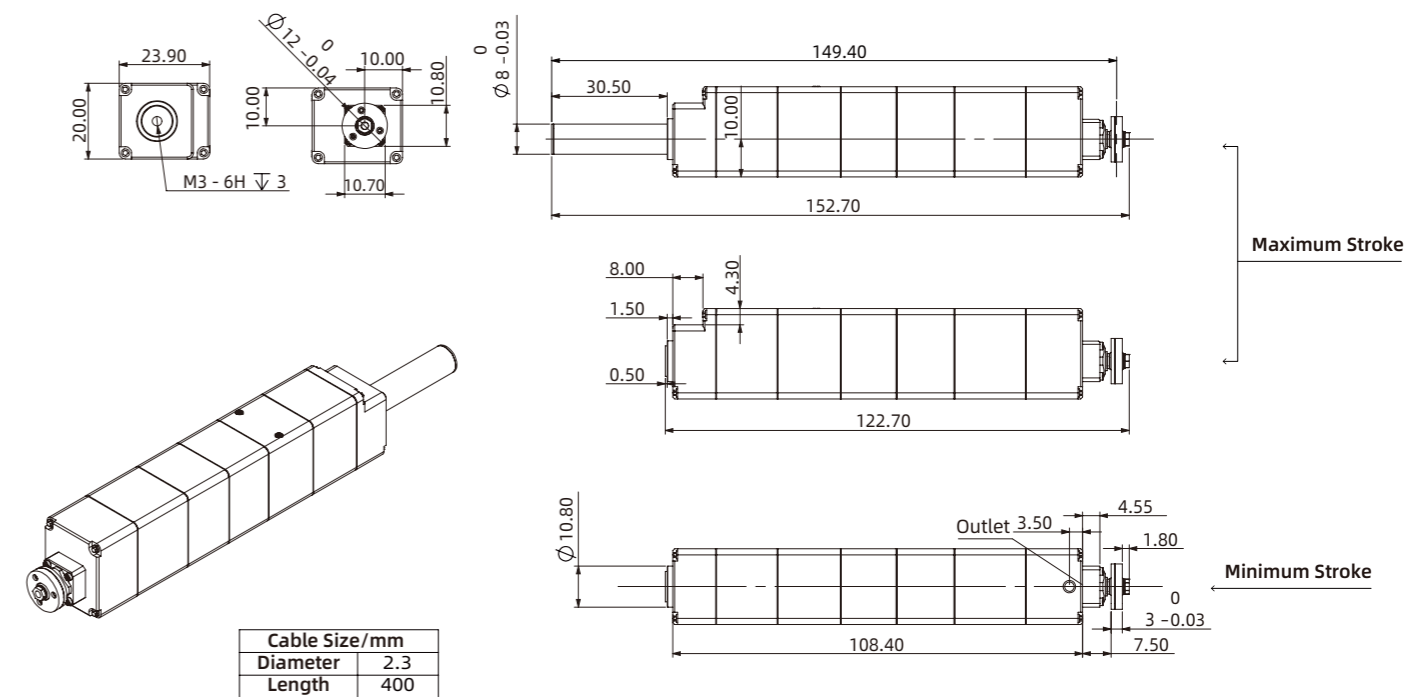

**Spherical Plain Bearing**

# Accessories

## Micro Linear Servo Actuator

### Octagonal Joint

MODEL : AMI-LA-ACBO-S20/S30/T20/T25/T30

Attention : The octagonal interface comes standard with an AMI-LA-ACBO-S30 octagonal joint, and the installation angle of the octagonal joint can be adjusted as required. In addition to AMI-LA-ACBO-S30, you can also purchase the following types of octagonal joints as needed.



### Actuator Joint

MODEL : AMI-LA-ACR1-S20/S30/T20/T25/T30

All models of actuators come standard with M3 standard internal thread, with a depth of 3mm, and actuator joint can be selected as required.



### Ball Joint

MODEL : AMI-LA-BR-P30

The front end of the actuator joint can also be equipped with a ball joint if needed. The ball joint have to be used with the actuator joint AMI-LA-ACR1-T30.

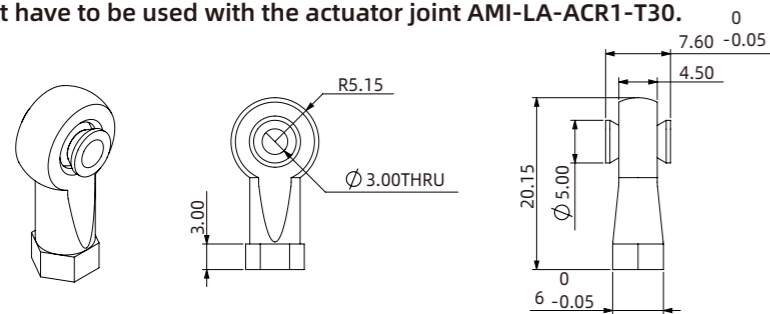

Dimensions of ball joint AMI-LA-BR-P30



### USB to LVTTTL Converter

MODEL : AES-LA-31-06 DIMENSIONS : 45X33X32MM

AES-LA-31-06 Converter converts USB signal input to LVTTTL 3.3V signal output, enabling drive control, parameter modification, and status query. Can connect to six micro linear servo actuators with different IDs.



### Joystick Controller

MODEL : AEC-LA-B1-02 DIMENSIONS : 60X30X50MM

AEC-LA-B1-02 Joystick Controller enables micro linear servo actuator control in two modes: manual joystick control and autonomous reciprocating motion.



### RS232 to LVTTTL Converter

MODEL : AES-LA-11-06 DIMENSIONS : 60X40X35MM

AES-LA-11-06 Converter converts RS232 level signal to LVTTTL 3.3V level signal to enable actuator control via RS232 Serial Port Signal.



### STM32 Controller

MODEL : AES-LA-71-0C DIMENSIONS : 60X40X50MM

AES-LA-71-0C is a STM32F103C8T6 controller with RS232 input and 12 channel LVTTTL 3.3V output, capable of simultaneous control for up to 12 micro linear actuators.



### Modbus RTU to LVTTTL Converter

MODEL : AED-LA-92-12MR1 DIMENSIONS : 110x50x24MM

AED-LA-92-12 Converter converts RS485 level to LVTTTL 3.3V level for RS485 servo control via Modbus RTU standard protocol, and/or acting as a 24V to 8V step-down module.

# THE DEXTEROUS HANDS

It adopts an innovative linear drive design and integrates 6PCS force controlled micro linear servo actuator. The hand has 6 degrees of freedom and 12 motion joints. The appearance is beautiful and highly simulated, combined with the force position hybrid control algorithm, it has sub-millimeter positioning accuracy and a load capacity of several kilograms, which can simulate human hands to perform tasks such as playing the piano and making tea, finger guessing game and other complex movements and precise grasping.

## APPLICATIONS



Humanoid Robots



Unmanned Laboratories



Industrial Automation



Education and Scientific Research



Prosthetics



Special Industries





# RH56BFX

## The Dexterous Hands

The RH56BFX series dexterous hand, known as the “piano hand” with fast speed, if it is equipped with the visual module, when playing finger guessing game, it can achieve a fake and real effect, which is suitable for play and gesture interaction.



Model	RH56BFX-2L	RH56BFX-2R
Side	The left hand	The right hand
Control interface	RS485	RS485
Degrees of freedom	6	6
Numbers of joints	12	12
Weight	540g	540g
Operating voltage	DC24V±10%	DC24V±10%
Quiescent current	0.20A	0.20A
Peak current	2A	2A
Repeatability	±0.20mm	±0.20mm
Maximum thumb grip	6N	6N
Maximum palm finger grip	4N	4N
Force resolution	0.50N	0.50N
Thumb lateral rotation range	> 65°	> 65°
Thumb lateral rotation speed	235°/s	235°/s
Thumb bend speed	150°/s	150°/s
Palm finger bend speed	570°/s	570°/s

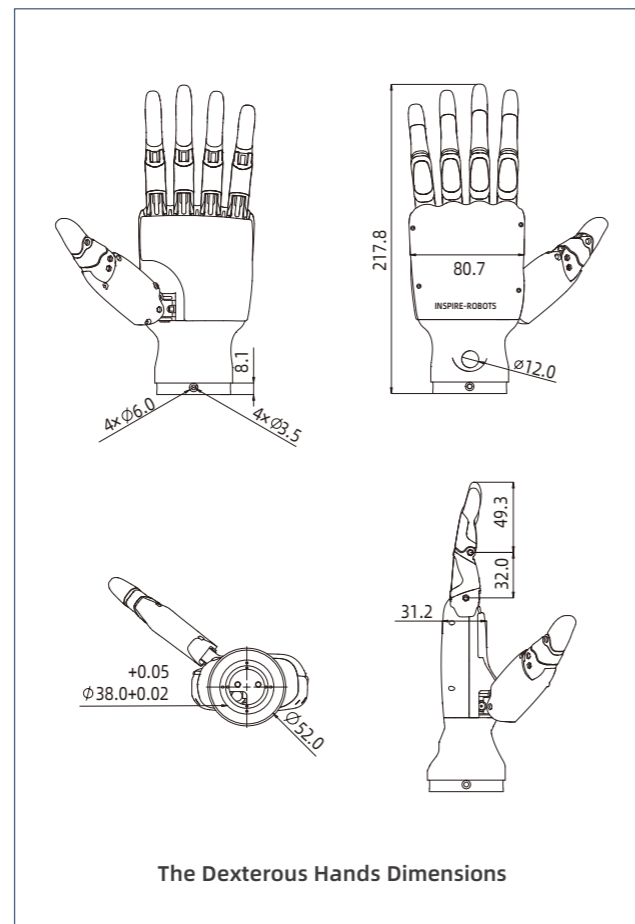

# RH56DFX

## The Dexterous Hands

The RH56DFX series dexterous hand, it can lift a 5KG bucket, and the fingertip grip strength reach up to 1.5KG, which is suitable for robotic end effectors or prosthetics.

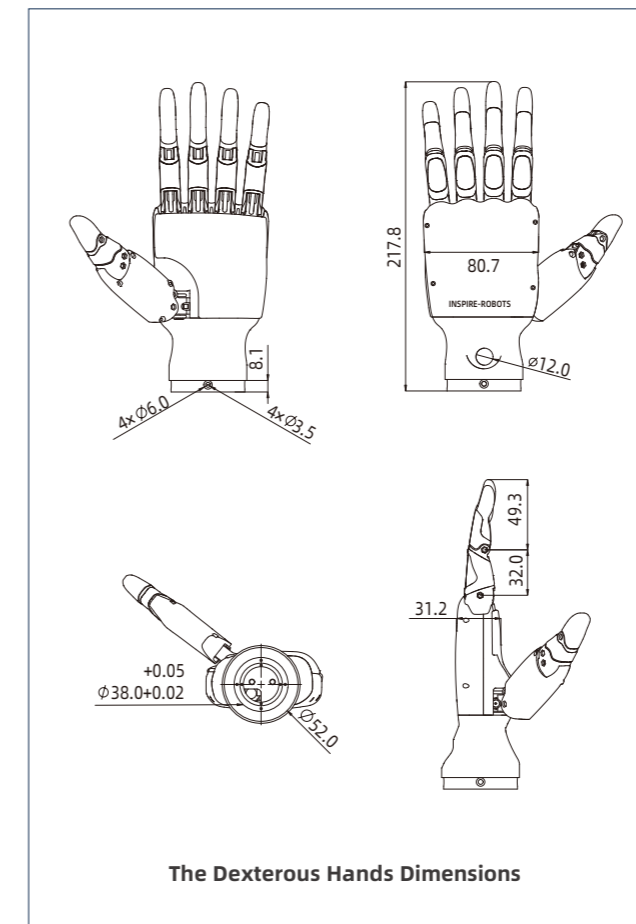

Model	RH56DFX-2L	RH56DFX-2R
Side	The left hand	The right hand
Control interface	RS485	RS485
Degrees of freedom	6	6
Numbers of joints	12	12
Weight	540g	540g
Operating voltage	DC24V±10%	DC24V±10%
Quiescent current	0.2A	0.2A
Peak current	2A	2A
Repeatability	±0.2mm	±0.2mm
Maximum thumb grip	15N	15N
Maximum palm finger grip	10N	10N
Force resolution	0.5N	0.5N
Thumb lateral rotation range	> 65°	> 65°
Thumb lateral rotation speed	107°/s	107°/s
Thumb bend speed	70°/s	70°/s
Palm finger bend speed	260°/s	260°/s

# Wrist with Double Degree of Freedom

MODEL : AMW-RH-12-2



Degree of freedom	2	
Yaw movement	Unloaded single-stroke motion period: 0.8s/54°	Range: ±27°
Pitch movement	Unloaded single-stroke motion period: 0.8s/44°	Range: ±22°
Load torque	2NM (Excluding hand weight)	
Weight	220g (wrist only) 650g (hand + wrist)	

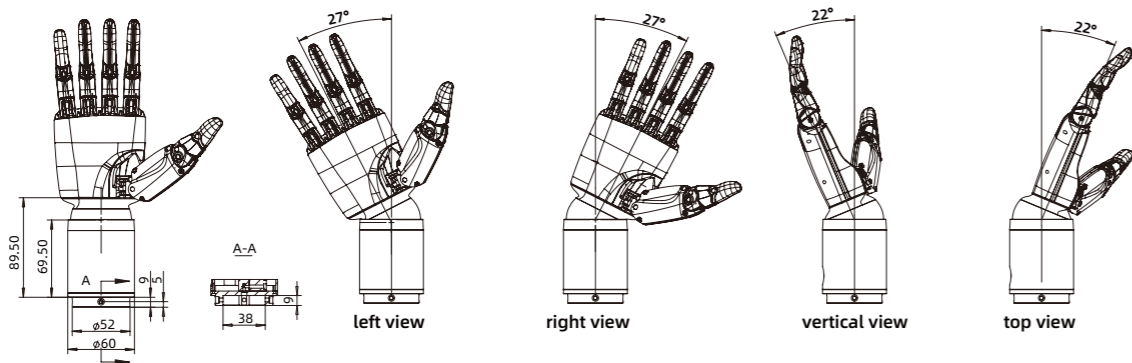

# ELECTRIC GRIPPER

Electric Gripper features controller integrated design, large stroke range, precise force and position control, drop detection, and self-lock even during power loss. Application includes biomedical automated inspection, automated sorting and loading/unloading on production lines, precision assembly, unmanned retail, service robotics, etc.

## APPLICATIONS

3C semiconductor

Precision machining and assembly

New energy industry

Unmanned retail

Automotive parts

Biomedical laboratory

## EXAMPLES



Loading and unloading

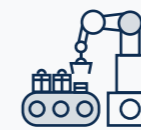

Sorting



Parts assembly

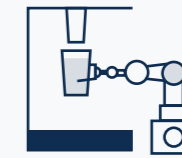

Unmanned retail

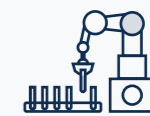

Scientific research experiments

## FEATURES OF ELECTRIC GRIPPER



Controller integrated



Large stroke, precisely



Grip force precisely and controllable



Power-off Self-locking

# EG2-4B2

## Electric Gripper



Features: Innovative linear mechanical linkage design, force and position control, large stroke, light weight, power off self-locking.

Model	EG2-4B2
Communication interface	RS485
Full stroke (both side)	70mm
Weight	223g
Grip force	0-15N
Force repeatability	±1N
Operating voltage	DC24V±10%
Idling current	30mA
Peak current	0.70A
Positioning repeatability	± 0.50mm
Full stroke closing time	0.85s
Unloaded current	200mA
Protection level	IP40
Recommended working temperature	0-40°C
Maximum speed	97mm/s

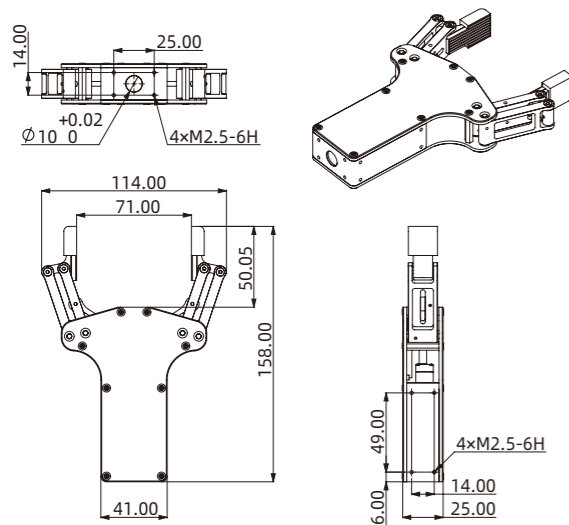

# EG2-4C2

## Electric Gripper



Features: Innovative linear mechanical linkage design, force and position control, large stroke, light weight, power off self-locking.

Model	EG2-4C2
Communication interface	RS485
Full stroke (both side)	70mm
Weight	231g
Grip force	0-20N
Force repeatability	±1N
Operating voltage	DC24V±10%
Idling current	30mA
Peak current	0.70A
Positioning repeatability	± 0.50mm
Full stroke closing time	1.3s
Unloaded current	200mA
Protection level	IP40
Recommended working temperature	0-40°C
Maximum speed	70mm/s

